

Installation Manual

LAMP®

FD80-AFH ALUMINUM FRAME SLIDING DOOR

Recessed Mount Roller, Two-Way Soft Close

Part No. FD80DHCHP-AF

Thank you for using our product. Before installation, please read this manual thoroughly to ensure correct installation. Please keep this manual at hand for future reference.

ABOUT THE PRODUCT

- This is a parts set for a heavy duty aluminum frame sliding door system for residential & commercial use.
- Built in soft closer enables two-way soft closing movement in both directions.
- Recessed mounted roller allows a small gap between the track and the door.
- There are two types of horizontal frame designs: the standard type and the slim type.

SPECIFICATIONS

Required number of intermediate supports (15)	0 (Without Intermediate support)	1	2	3
Door height	Max.2200 mm		2201- 2700 mm	
Door width	784- 900 mm		901 - 1500 mm	
Glass thickness	5 mm or 6 mm			
Max. Door weight	80 kg / door			
Vertical adjustment	1 mm upward, 4 mm downward			

- The closing speed of the soft closing type door may change depending on the ambient temperature, operating method or installation quality.
- Recommended ambient temperature range is 5 to 40° C.

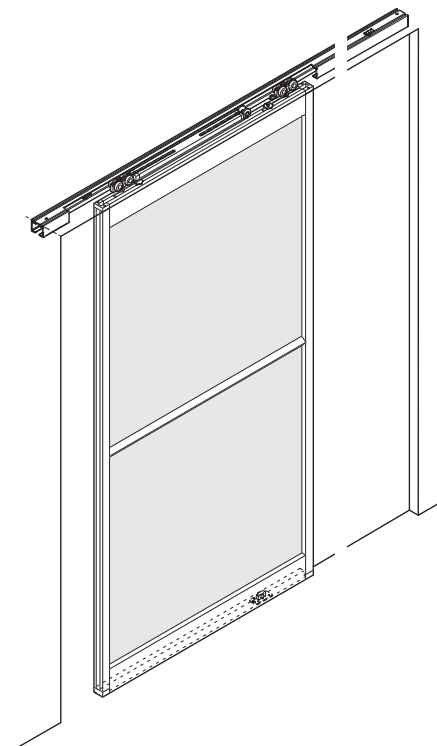

FOR YOUR SAFETY WORK AND CORRECT INSTALLATION

Meaning of symbols

 Warning Caution	 Prohibited	 Required
--	---	---

WARNING: If not followed, death or serious injury may result.

- ❗ This product should be installed by a qualified person in accordance with this manual. If it is not installed correctly, the door may fall and cause injury.
- ❗ Provide a frame that can withstand the weight and impact of opening and closing the door. Be sure to use the specified screws and tighten them securely. If the mounting strength is insufficient, the door may fall and cause injury.
- ⊘ Do not use this product for any other purpose, or with doors that are outside the specifications of this manual.
- ⊘ Do not disassemble or modify any parts other than those described in this document.

Caution: If not followed injury or damage may result.



- ❗ Use tempered glass. Using shatter-proof film is recommended.
- ❗ Follow the specified dimensions, specifications, and alignment of the door and frame. Warping, tilting or twisting of the frame or door may cause failure.
- ❗ If cutting any parts, make sure to remove any burrs before installation. Also check the upper track for any left-over burrs or scraps and remove these.
- ❗ This product is a part for architectural fittings. After installation, please check the function and safety of the final product. Please inform the end user how to use the product safely.
- ❗ Make sure to check the screws for slack at regular intervals (one month from first usage, half a year, and then one time every year is recommended).

COMPONENT PARTS

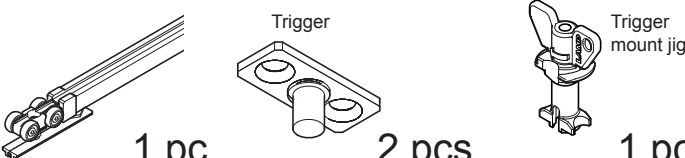
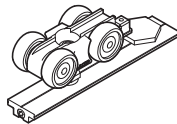
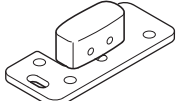
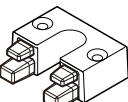
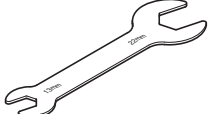

Parts set (FD80DHCHP-AF) per door

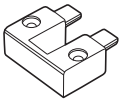
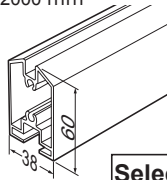
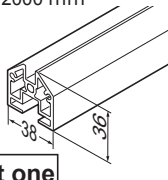
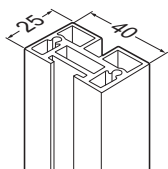
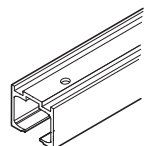
<p>① Soft Closer + Trigger + Jig Accessory : Countersunk head tapping screw 4 × 30 D6 4 pcs (for Trigger) : Hex key 3 mm</p>  <p>1 pc 2 pcs 1 pc</p>	<p>② Upper roller Accessory: Hex key 3 mm</p>  <p>1 pc</p>	<p>③ Floor guide S Accessory : Bind head tapping screw 4 × 16 5 pcs</p>  <p>1 pc</p>
<p>④ End cap</p>  <p>2 pcs</p>	<p>⑤ Spanner</p>  <p>1 pc</p>	

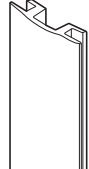
Required Parts

<p>⑥ Corner Part</p>  <p>2 pcs / door</p>	<p>⑦ Mounting screw set (for selection of frame type ⑧)</p> <ul style="list-style-type: none"> Hexagon socket head cap screw M6 × 30 8 pcs (for Frame ⑧⑩) Hexagon socket head cap screw M4 × 30 6 pcs (for Intermediate support ⑮) Hexagon socket countersunk head screw (for Corner Part ⑥) M4 × 25 8 pcs <p>1 set</p>	<p>⑦ Mounting screw set (for selection of frame type ⑨)</p> <ul style="list-style-type: none"> Hexagon socket head cap screw M6 × 30 4 pcs (for Frame ⑨⑩) Hexagon socket head cap screw M4 × 30 6 pcs (For mounting the crosspiece frame ⑮, use two pieces per piece) Hexagon socket countersunk head screw M4 × 25 (for corner parts ⑥) 8 pcs Grooved pins 4 × 20 10 pcs (including 2 spare pins) <p>1 set</p>	<p>⑧ Horizontal frame 2000 mm</p> 	<p>⑨ Horizontal frame (For slim type) 2000 mm</p>  <p>Select one</p>
<p>⑩ Vertical frame 2500 mm/3000 mm</p> 	<p>⑪ Upper track 2000 mm ~ 3640 mm (Various sizes) Accessory : Pan head tapping screw 5 × 40</p> 	<p>⑫ Gasket for 5 mm glass: 2500 mm for 6 mm glass: 3000 mm</p> 	<p>⑬ Edge cover 2500 mm/3000 mm</p> 	

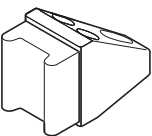
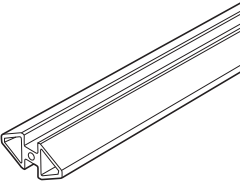
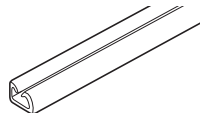
Optional parts

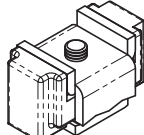
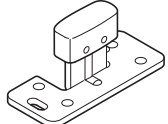
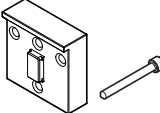
<p>⑭ Door stopper (floor mounted) Item No. FD30-HTKY Accessory : Bind head tapping screw 4 × 30 3 pcs Needed when vertical frame is not used</p> 	<p>⑮ Intermediate support Item No. : AF-25-W03 type 2000 mm</p> 	<p>⑯ Gasket for Intermediate support Item No. : for 5 mm glass AF-25-P03 type for 6 mm glass AF-25-P16 type 2500 mm Used as a set with the Intermediate support ⑮</p> 	<p>⑰ Handle Item No. : MN799Z160E type It is adhered after drilling two 7 mm dia. holes.</p> 
<p>⑱ Stopper block Item No. FD80-HSB This is used in the upper track</p> 	<p>⑲ Floor guide L Item No. : FD50-BG32 Accessory : Bind head tapping screw 4 × 16 5 pcs This is used when larger space below the door is required.</p> 	<p>⑳ Jig set for punches Item No. : AF-25-JIG-SET</p>  <p>Horizontal frame (slim) recommends the use of punch jigs and pins</p>	

INSTALLATION DRAWING (EXAMPLE)

Refer to page 4 about the dimensions of the doors and glass panels.

Caution

When vertical frame is not used, use a door stopper(floor) 14 and stopper block 18

Double sliding

Part set: Use 2 sets of FD80DHCHP-AF

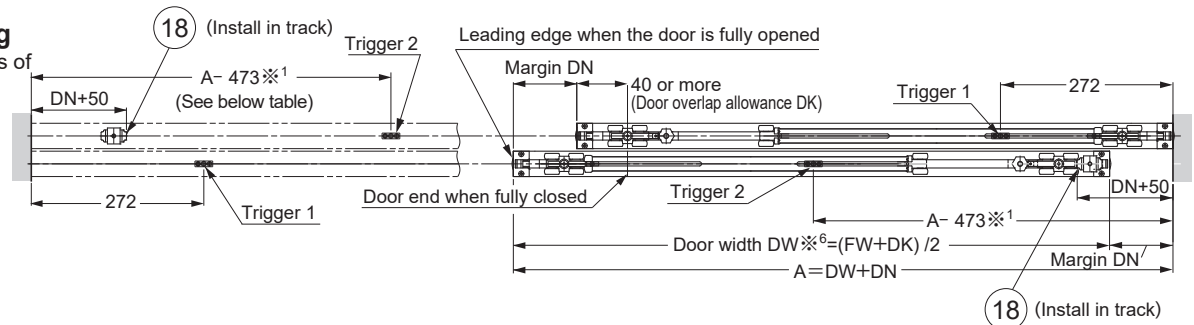

Single sliding

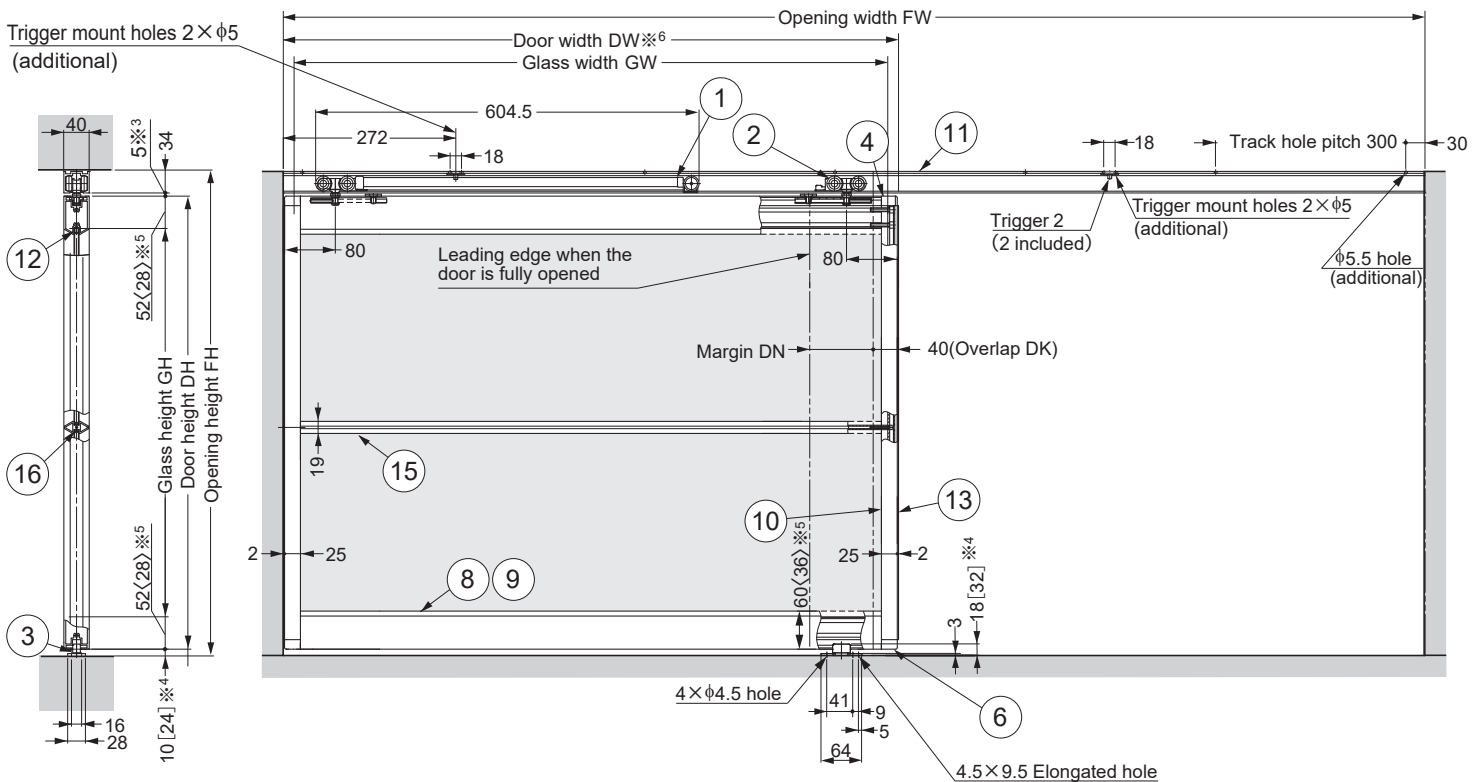
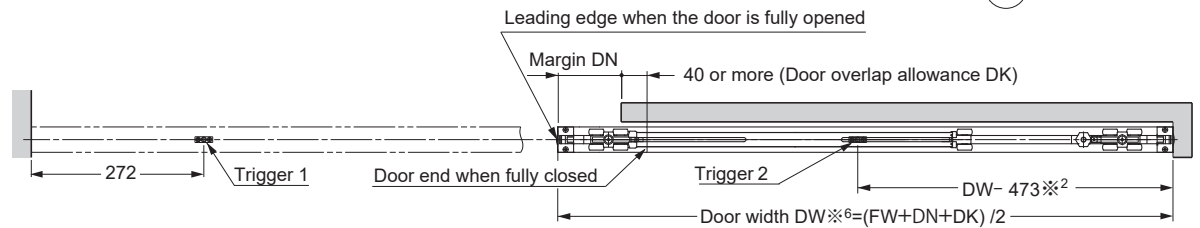

DIMENSIONS OF DOORS

(Round off the decimal point for the divided dimensions.)

■ Drawing of installed door

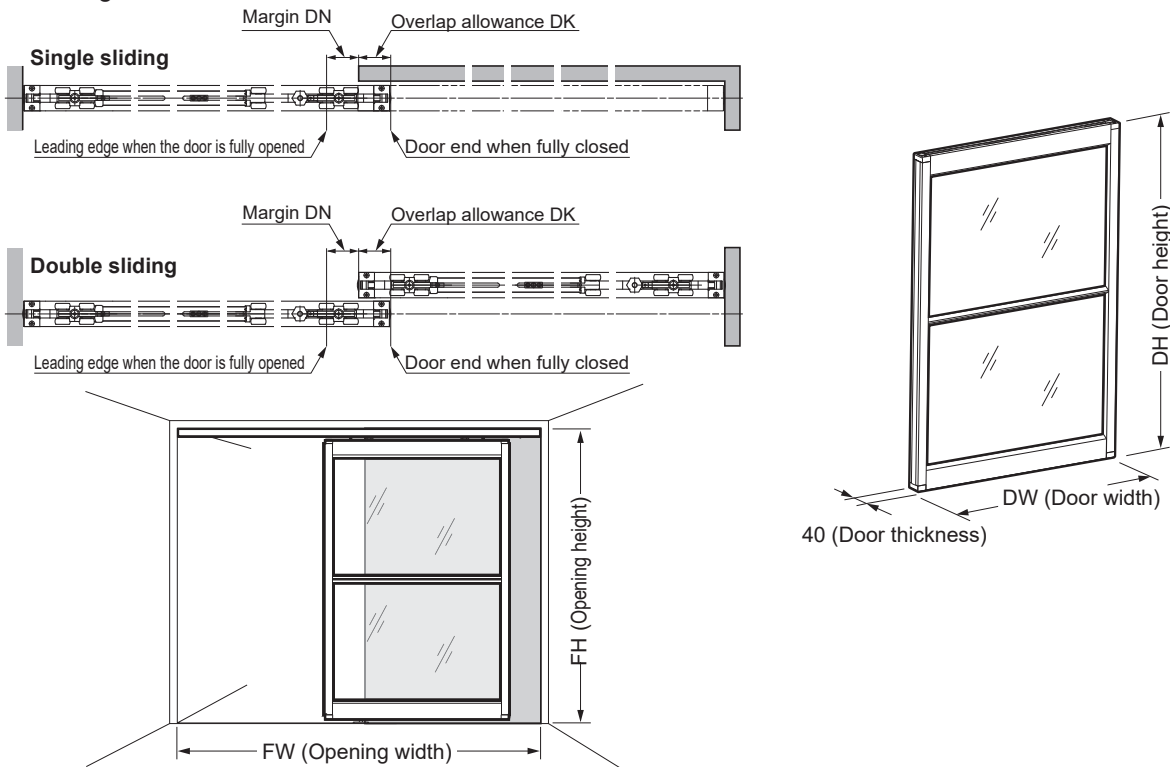

⑧ When using the horizontal frame [Dimension] is when ⑱ Lower guide L is used.

$$DH(\text{opening height}) = FH - 49 \quad [63]$$

$$\text{Single } DW(\text{Door width}) = \frac{FW + \text{Door residual } DN + 40 \text{ or more (Overlap allowance DK)}}{2}$$

$$\text{Binding } DW(\text{Door width}) = \frac{FW + 40 \text{ or more (overlapping allowance DK)}}{2}$$

$$GH(\text{glass height}) = \frac{DH - 104 - (\text{Number of Intermediate support } \textcircled{15} \times 11)}{\text{Number of glass panels}}$$

$$GW(\text{glass width}) = DW - 38$$

⑨ When using the horizontal frame (slim)

$$DH(\text{opening height}) = FH - 49 \quad [63]$$

$$\text{Single } DW(\text{Door width}) = \frac{FW + \text{Door residual } DN + 40 \text{ or more (Overlap allowance DK)}}{2}$$

$$\text{Binding } DW(\text{Door width}) = \frac{FW + 40 \text{ or more (overlapping allowance DK)}}{2}$$

$$GH(\text{glass height}) = \frac{DH - 56 - (\text{Number of Intermediate support } \textcircled{15} \times 11)}{\text{Number of glass panels}}$$

$$GW(\text{glass width}) = DW - 38$$

Example 1

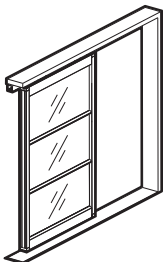

Ex: 1 door on single track

Size per Door when opening width is 1800 mm, opening height is 2200 mm, Door residue is 80 mm, and overlapping allowance is 40 mm

$$DH = 2200 - 49$$

$$= 2151 \text{ mm}$$

$$DW = \frac{1800 + 80 + 40}{2}$$

$$= 960 \text{ mm}$$

Example 2

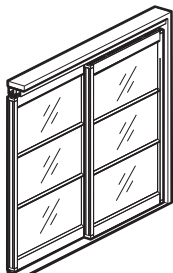

Ex: 2 door on double track

Size of each door with Opening width 1800 mm, Opening height 2400 mm and Overlap 40 mm.

$$DH = 2200 - 49$$

$$= 2151 \text{ mm}$$

$$DW = \frac{1800 + 40(\text{Overlap allowance DK})}{2}$$

$$= 920 \text{ mm}$$

1 Cutting and Drilling Components

⚠ Caution

- ❗ Cut carefully so the cut edge is square to avoid bias and skewing.
- ❗ When cutting, reinforce the track to prevent deformation at the cut section.

[1] Processing of Upper track ⑪

- (1) Length = FW (Opening width)
- (2) Refer to the figure on the right for cutting and drilling holes.

⚠ Caution

- ❗ Remove any dirt or aluminum chips from the track.

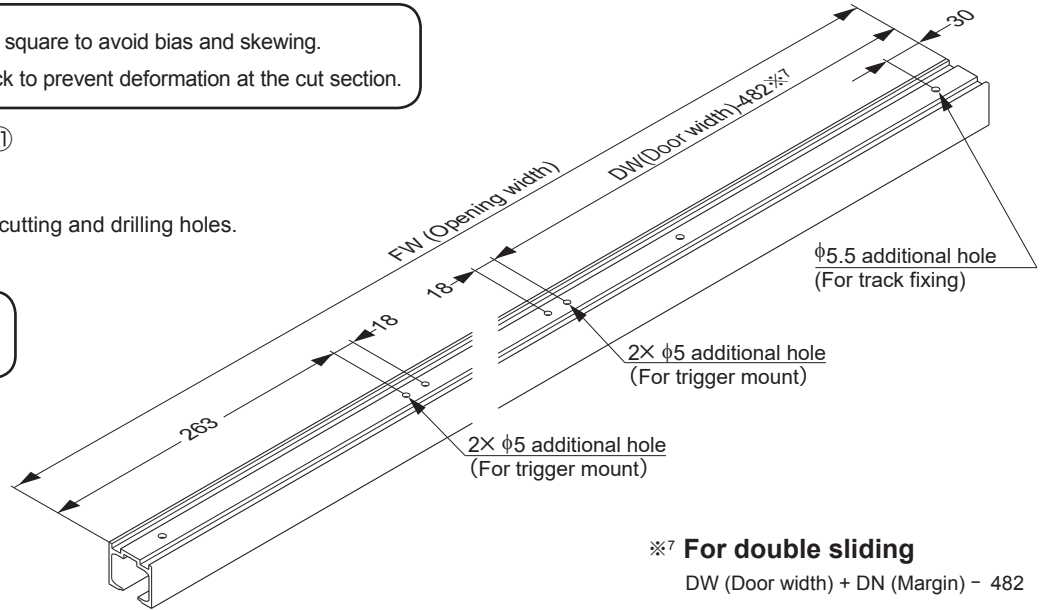

[2] Processing of Horizontal frame ⑧, ⑨

Length = DW(Door width) - 50(Thickness of vertical frame ⑩ × 2) - 4(Edge cover ⑬ × 2)

⑧ Horizontal frame

⑨ Horizontal frame (slim)

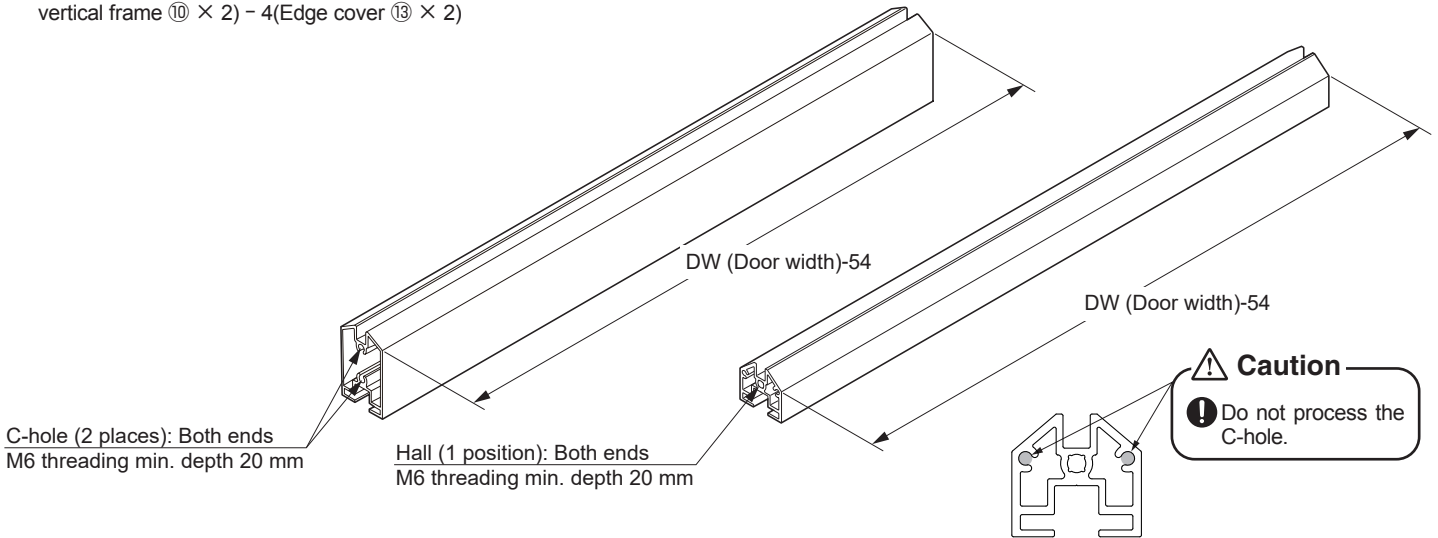

[3] Cutting and hole processing of Intermediate support ⑮, when used

Length = DW(Door width) - 50(Thickness of vertical frame ⑩ × 2) - 4(Edge cover ⑬ × 2)

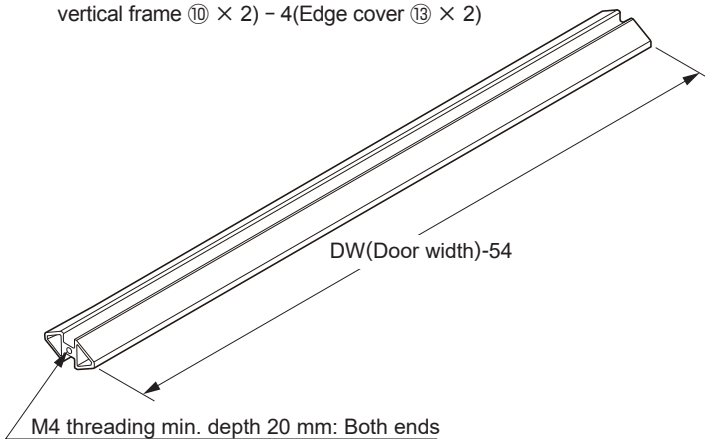

[4] Processing of Vertical frame ⑩ - Step 1

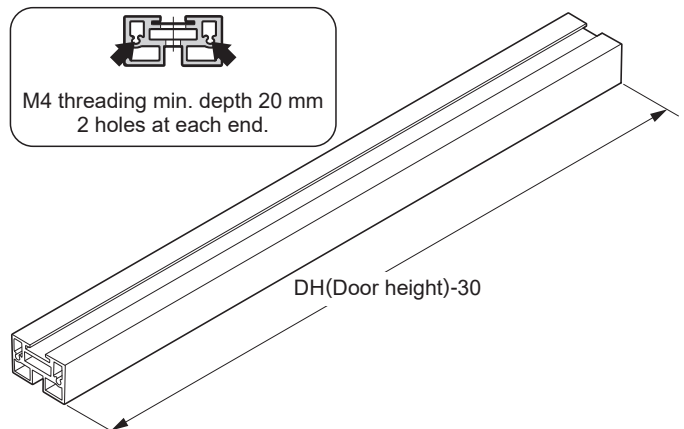

[5] Processing of Vertical frame ⑩ - Step 2 (for A-hole/C-hole machining)

A hole drilling (⑧ only)

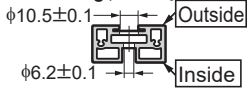

⑧ For horizontal frame

Hole A only if there is no intermediate support ⑮
 Hole A + B② for 1 intermediate support ⑮
 Hole A + B①, B③ for 2 intermediate supports ⑮
 Hole A + B①, B②, B③ for 3 intermediate supports ⑮
 DH=Door height
 GH=glass height

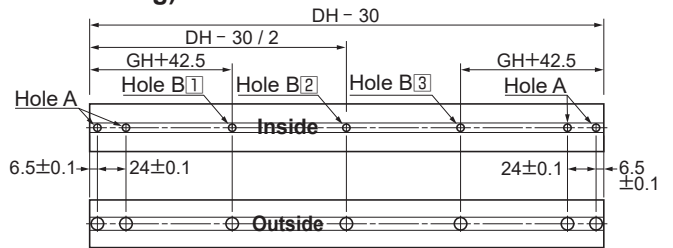

B Hole drilling

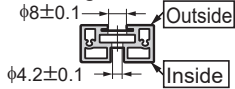

⑨ For horizontal frame (slim)

Hole C only if there is no intermediate support ⑮
 Hole C + B② for 1 intermediate support ⑮
 Hole C + B①, B③ for 2 intermediate supports ⑮
 Hole C + B①, B②, B③ for 3 intermediate supports ⑮
 DH=Door height
 GH=glass height

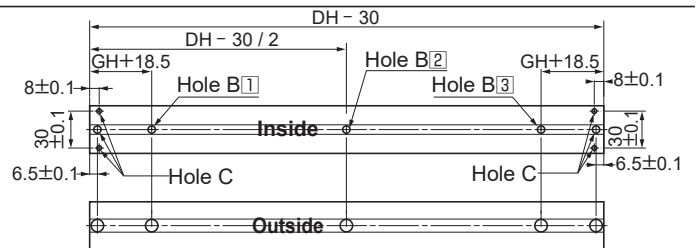

C hole drilling (⑨ only)

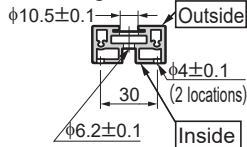

⑳ Hole machining using a punch jig (for A-hole/C-hole machining)

When using the horizontal frame (slim) ⑨, jig ⑳ for punch is recommended.

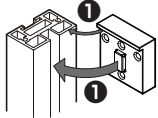

① Hook the jig on the upper edge of the vertical frame and the groove.

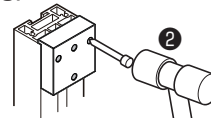
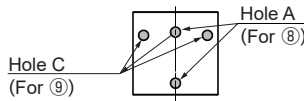

② After striking the punch, drill the holes according to the figure on the left.

2 Assembling Parts

[1] Verification before installing soft closer ①

Caution
 Without verification the selfclosing feature may fail.

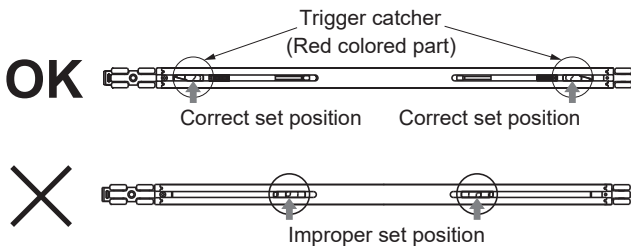

If the trigger position is wrong, pull back the trigger catcher to the correct position using a 6 mm diameter round bar.

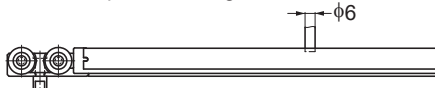

[2] Inserting Parts into Upper Track

Insert the parts in order from ① ② .

Caution
 ① Tape around rollers and upper track to prevent inserted parts from falling.

When using the stopper block ⑱, insert it before ① .

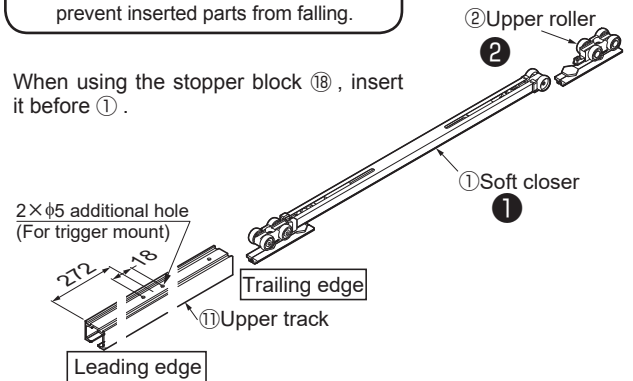

3 Mounting the Upper Track ⑪, Trigger ①, and Floor Guide

[1] Mounting the Upper track ⑪

Fasten the upper track with provided screws.

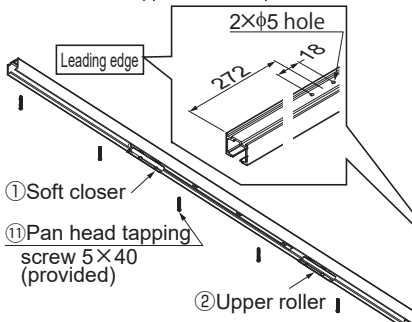

[2] Fastening the Trigger ①

How to use the trigger mounting jig

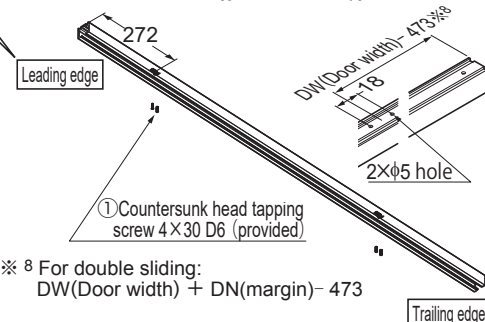
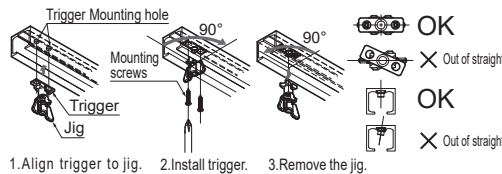

※ 8 For double sliding:
 DW(Door width) + DN(margin) - 473

[3] Mounting the Floor guide ③

(1) Position floor guide just below the center of the upper track ⑪.
 (2) With the door closed, adjust the floor guide position so that the protruding part does not come into contact with the edge of the corner part ⑥. Then fit with supplied screws.

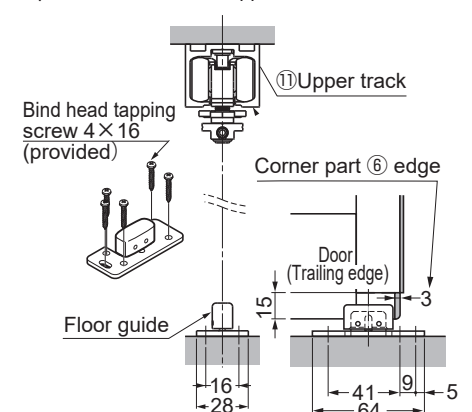

4 Assembling Door

⚠ Caution

- ❗ Coat screw threads with an anti-backoff material such as "thread locking".
- ⚠ During door installation, handle the glass carefully to prevent injury.

[1] Assembly of Horizontal frame ⑧, ⑨ (lower) and Vertical frame ⑩

⑧ Horizontal frame

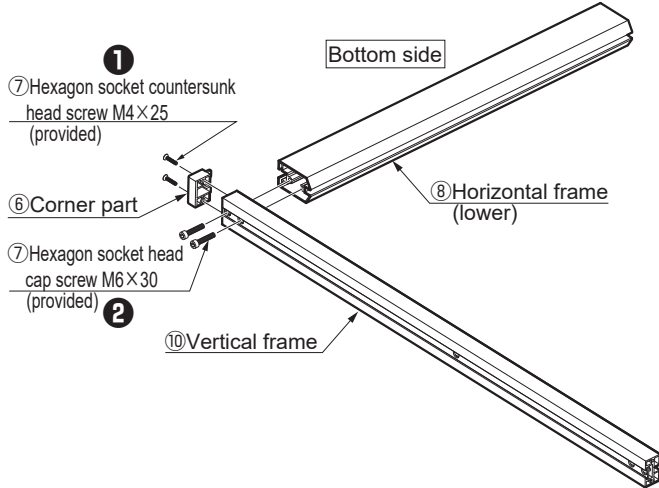

⑨ Horizontal frame (slim)

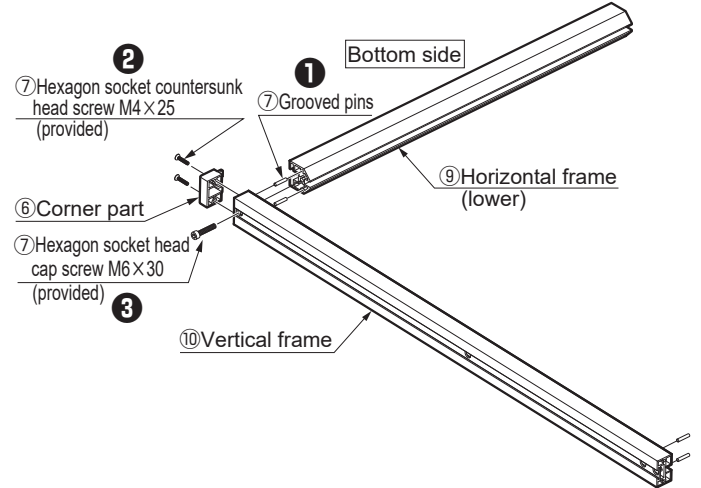

Placement of grooved pins

The grooved pins of other parts should be driven prior to assembly.

When not using a jig

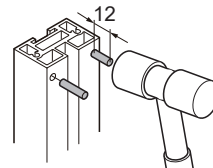

Implement up to 12 mm (top and bottom 4 pcs.)

When using a jig

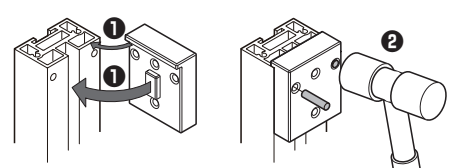

① Hook the jig on the upper edge of the vertical frame and the groove.
② Drive the jig until it is flush with the surface (top and bottom 4 pcs.)

The following mounting, adjustment and door removal procedures are explained using the horizontal frame ⑧.

[2] Insertion of glass - Step 1

(The following mounting, adjustment and door removal procedures are explained using the horizontal frame ⑧.)

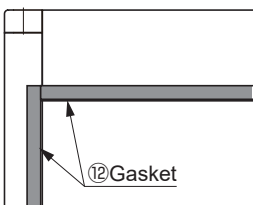
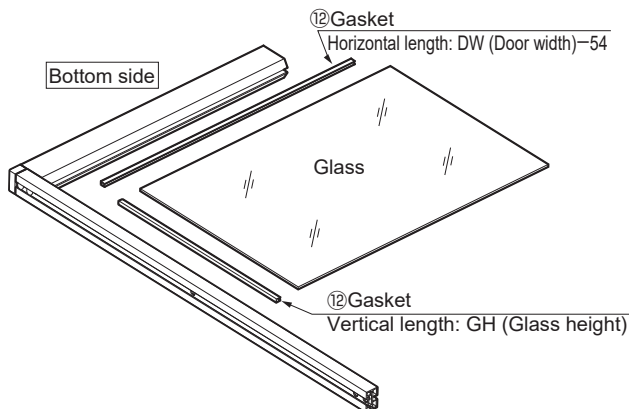

[3] Assembly of Intermediate support ⑮, when used

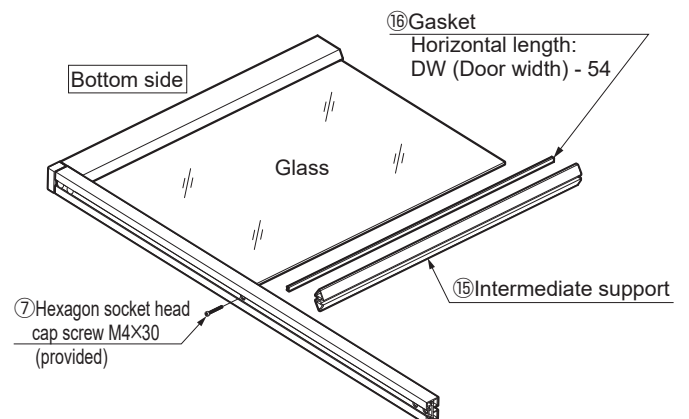

[4] Insertion of glass - Step 2, when Intermediate support is used

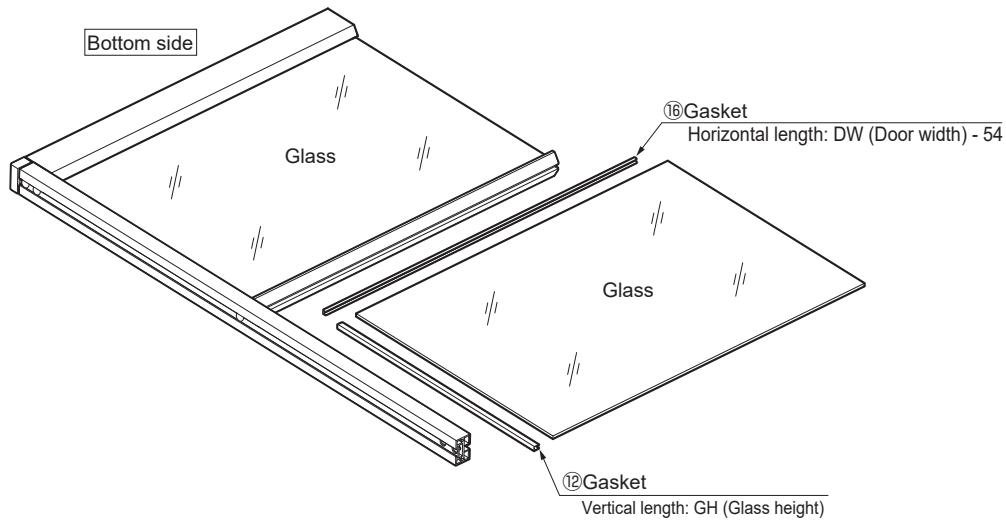

When using more than two Intermediate supports, repeat procedures 4- [3] to 4- [4] .

[5] Assembly of Horizontal frame ⑧, ⑨ (upper)

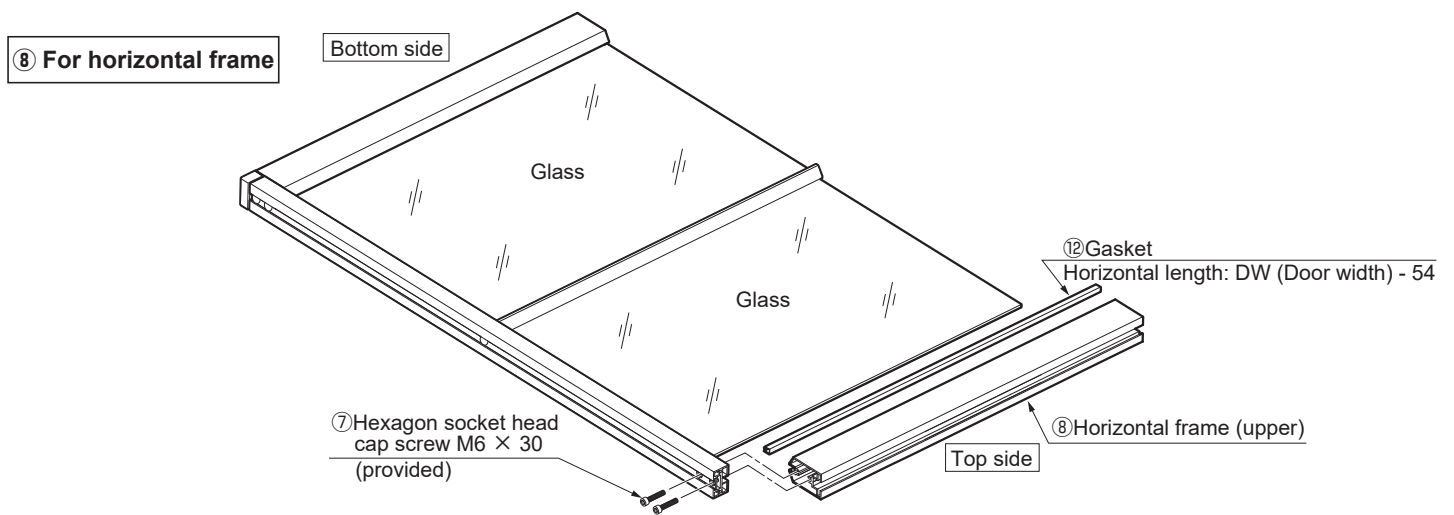

⑨ For horizontal frame (slim)

Refer to [1] on P.7 for the installation of grooved pins ⑦ .

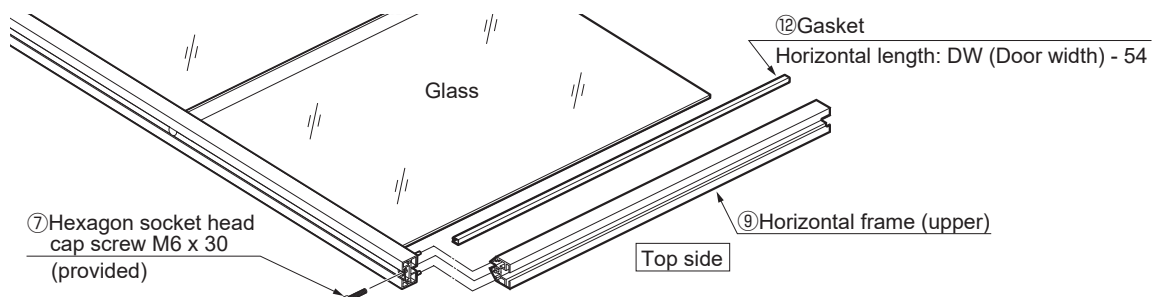

[6] Assembly of Vertical frame ⑩

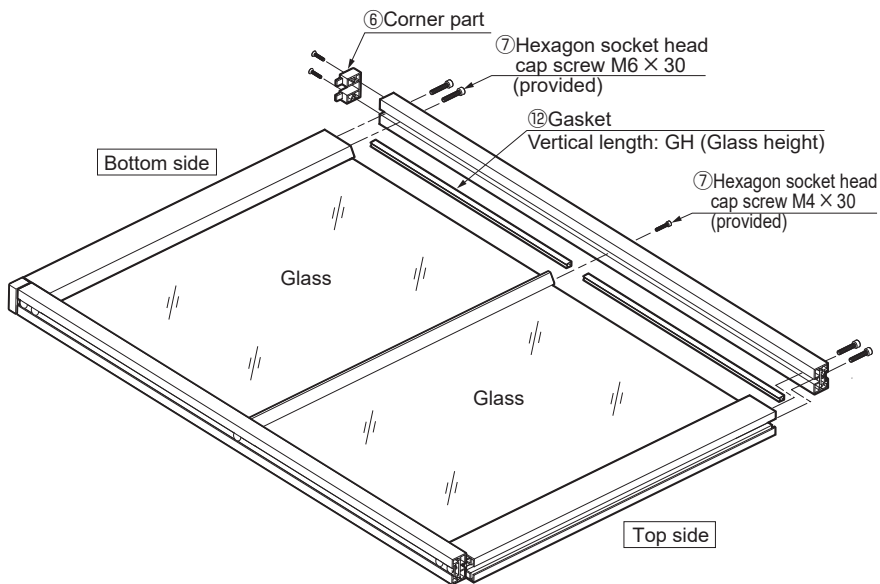

⑨ Horizontal frame (slim)

Refer to [1] on P.7 for the installation of ⑦ grooved pins.

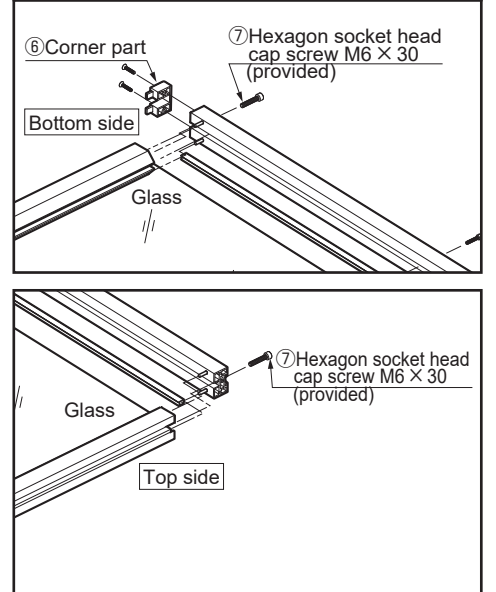

You may find the gasket ⑫ coming off from the frame.
In such case, use a scraper or something to push it in and be careful not to scratch the glass.

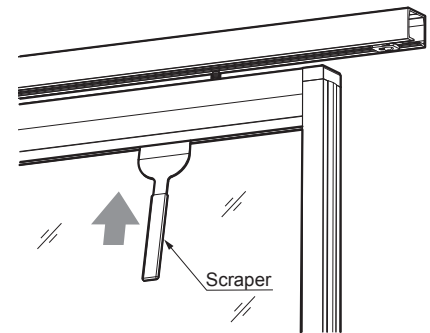

[7] Assembly of Edge covers ⑬

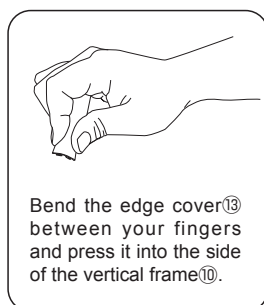
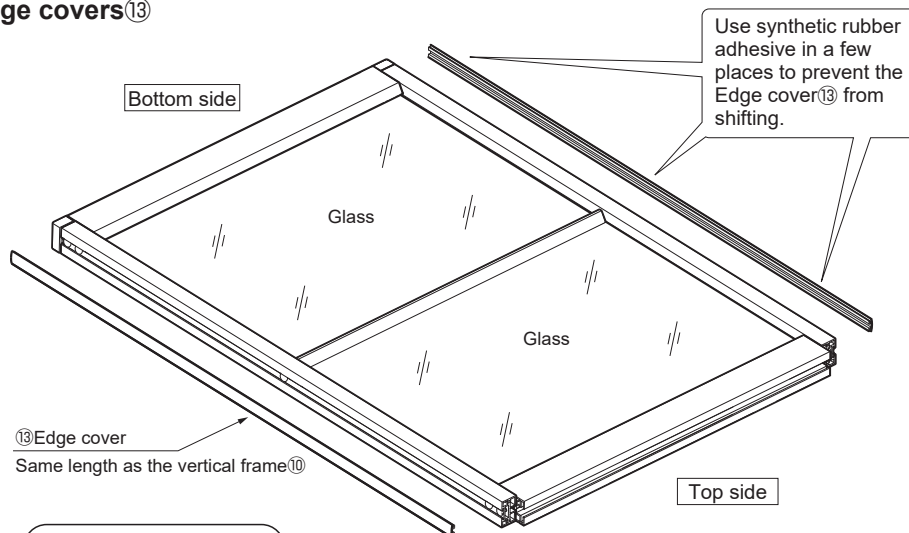

⚠ Caution

❗ Before attaching the edge covers ⑬, make sure the frame is not biased or skewed, and that all bolts are tight. Make sure the parts are firmly assembled and there is no warping or skewing.

5 Hanging the Door

- [1]** Put a support below the door to be hanged. Tilt the door as shown in the figure, and set the floor guide S③ to the groove of the bottom horizontal frame ⑧ (⑨).
- [2]** Insert the fixing plate of the roller in the horizontal frame ⑧ (⑨) as shown in the figure below.

⚠ Caution

❗ Be sure to have someone with knowledge and experience assist you.

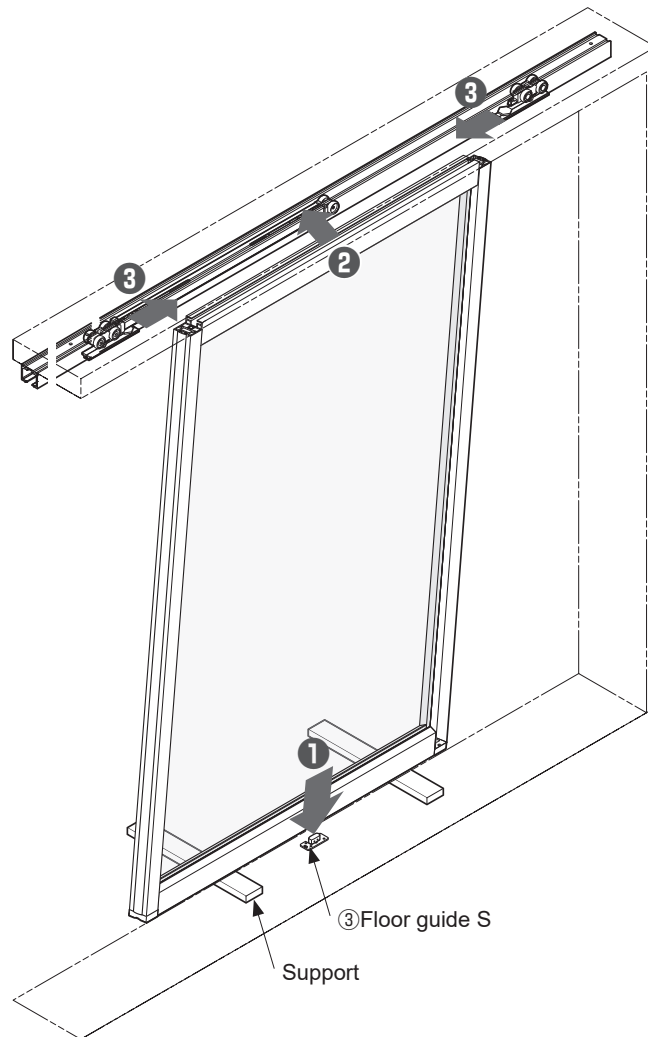

- [3]** Position the roller at 14 mm from the end of horizontal frame ⑧ (⑨), then fix it with provided spanner ⑤.

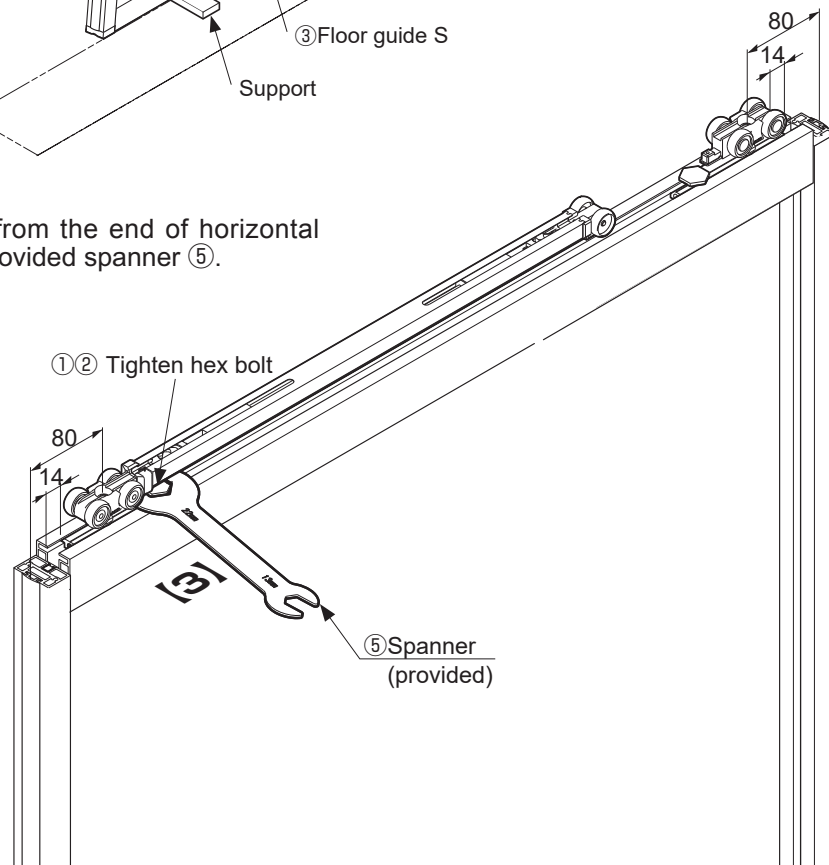

6 Adjustment of Door Height

- [1] Remove the support from under the door.
- [2] Adjust the door parallel to the upper track with 6-11 mm clearance between door and floor.
Then, tighten the vertical adjustment screw.
- [3] Fix the position with provided hex key.

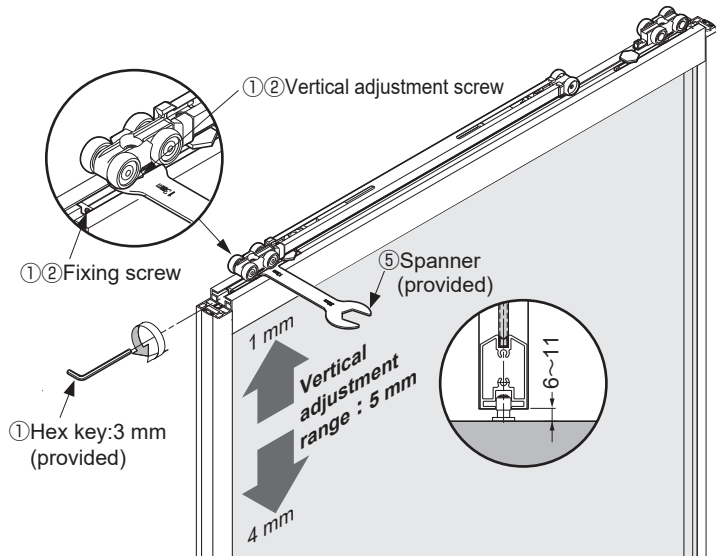

- [4] Put the end cap (4) on both ends of the door.

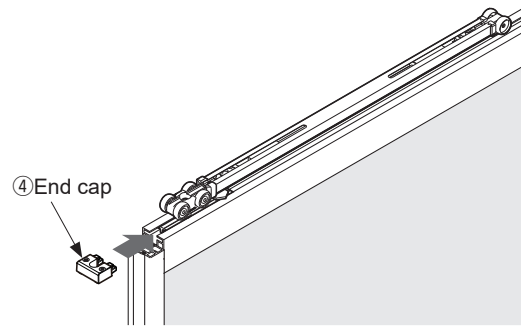

7 Checking Soft Closer Operation

- [1] Close the door slowly and check that the soft closer works correctly.
The soft closer is engaged approximately 115 mm at the leading edge before the door reaches its final position.
- [2] Carry out similar verification for the door trailing edge.
- [3] Please refer to the "TROUBLESHOOTING" section when the soft closer does not work correctly.

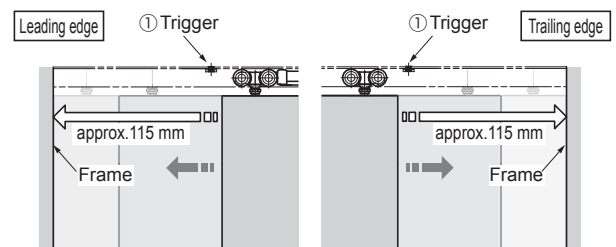

Caution

- ⊘ Do not close the door with excessive force.
It may cause damage to the soft close mechanism.

8 Mounting the Door Stopper (Optional)

When vertical frame is not used, use a door stopper (14) of optional.

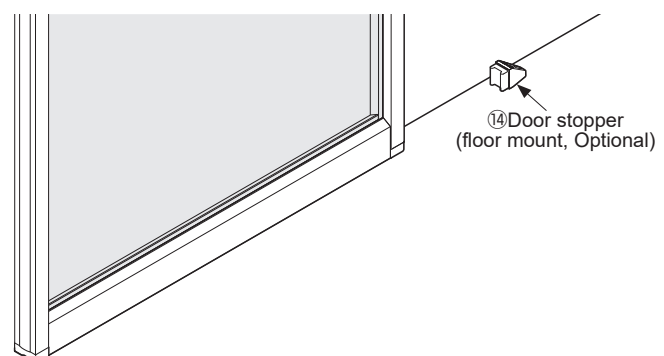

HOW TO REMOVE DOOR

⚠ Caution

❗ Be careful not to let the door fall.

[1] Put a 10 mm support under the door.

[2] Pull out the end cap.

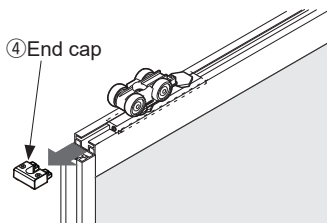

[3] Loosen the fix bolt with provided spanner.

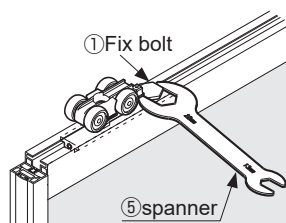

[4] Pull out the upper roller from the horizontal frame.

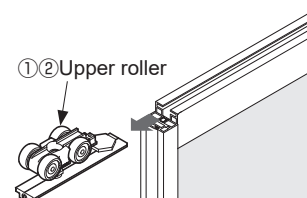

[5] Remove the door from the floor guide.

Final verification Verify that all screws are securely tightened, and verify that all screws have been used.

Periodical Inspection

- Clean the inside of the track.
- Check the upper and lower space of the door. If necessary, correct the space.

TROUBLESHOOTING

Trouble	Checkpoint	Solution
Door stops during soft closing	Check if door bottom contacts the floor or floor guide.	Verify that track mounting screws are not loosened. Then, adjust the door height such that the clearance between the door bottom and floor is 6 - 11 mm.
	Check if upper track is set horizontally.	Using a level gauge, reset the upper track horizontally.
	Check if mohair seal is installed.	Reduce the friction between the mohair seal and door.
No soft closing	Check if trigger is installed.	Install trigger to specified position.
	Check if door is closed by excessive force.	Do not close door by excessive force as it may damage the soft closer.
	The position of the trigger catcher in page 6 section 2 may become dislocated. (It is hidden as installed in upper track.)	Remove the door and the upper track, then check the status of the trigger catcher in section 2.
Abnormal noise during operation	Check if door bottom contacts with floor or floor guide.	Verify that track mounting screws are not loosened. Then, adjust the door height such that the clearance between the door bottom and floor is 6 - 11 mm.
	Check if door touches adjacent parts.	Adjust position of the floor guide to avoid contact with adjacent parts.
	Check track rollers for aluminum dust.	Remove the track and pull out the roller. Then, clean the roller.
	Check the track mounting screws for looseness.	Retighten the screws to free the roller.
Heavy door operation	Check if door bottom contacts with floor or floor guide.	Verify that track fixing screws are not loosened. Then, adjust the door height such that the clearance between the door bottom and floor is 6 - 11 mm.
Door does not move.	Check the track mounting screws for looseness.	Retighten screws to free the roller.
Door starts to move.	Check if the upper track is set horizontally.	Using a level gauge, reset the upper track horizontally.

SUGATSUNE KOGYO CO.,LTD

Tokyo, JAPAN
Phone: +81 (0)3 3866 2260 E-mail:export@sugatsune.co.jp

SUGATSUNE KOGYO (UK) LTD

Reading, UK
Phone: +44 118 9272 955 E-mail:sales@sugatsune.co.uk

SUGATSUNE EUROPE GmbH

Düsseldorf, GERMANY
Phone: +49 211 53812900 E-mail:sales@sugatsune.eu

ISO9001(Japan Offices and Sugatsune America) and ISO14001(Chiba Production division and Logistics center), certified.

SUGATSUNE SHANGHAI Co., LTD

Shanghai, CHINA
Phone: +86 21 3632 1858 E-mail:lamp@sugatsune.com.cn

Guangzhou, CHINA

Phone: +86 20 6639 3552 E-mail:lamp@sugatsune.com.cn

SUGATSUNE KOGYO INDIA PRIVATE LIMITED

Mumbai, INDIA
Phone: +91 22 28314490/91 E-mail:sales@sugatsune.in

SUGATSUNE AMERICA, INC

California, USA
Phone: +1 310 329 6373 E-mail:sales@sugatsune.com

Chicago, USA

Phone: +1 630 317 7072 E-mail:sales@sugatsune.com

SUGATSUNE CANADA, INC.

Phone: +1 514 312 5267 E-mail:support@sugatsune.ca

2022.08 0589-11