

# LAMP® FD30-H SLIDING DOOR SYSTEM Installation Manual (Two-Way Soft Close, Recessed Mount Roller)

Part No.FD30DHCP

Thank you for selecting our product. Before installation, please read this manual thoroughly to ensure correct installation. Please keep this manual at hand for future reference.

## ABOUT THE PRODUCT

- This product is a parts set for an indoor use sliding door system.
- The door closes in 2 soft motion steps; first slow, then fast, and opens with 1 step soft motion.
- Easy door installation and adjustment.

## SPECIFICATIONS

Max. Door height	2400 mm
Max. Door width	590 – 1000 mm
Min. Door thickness	24 mm
Max. Door weight	30 kg ※ <sup>1</sup>
Height adjustment range	3mm upward, 4 mm downward
Forward / backward adjustment	±2 mm

- The closing speed of the soft closing type door may change due to ambient temperature, operating method or installation quality.
- Recommended ambient temperature range is 5 to 40°C.
- ※<sup>1</sup>If a light weight door is applied, you may feel the resistance of the soft closer when opening the door.

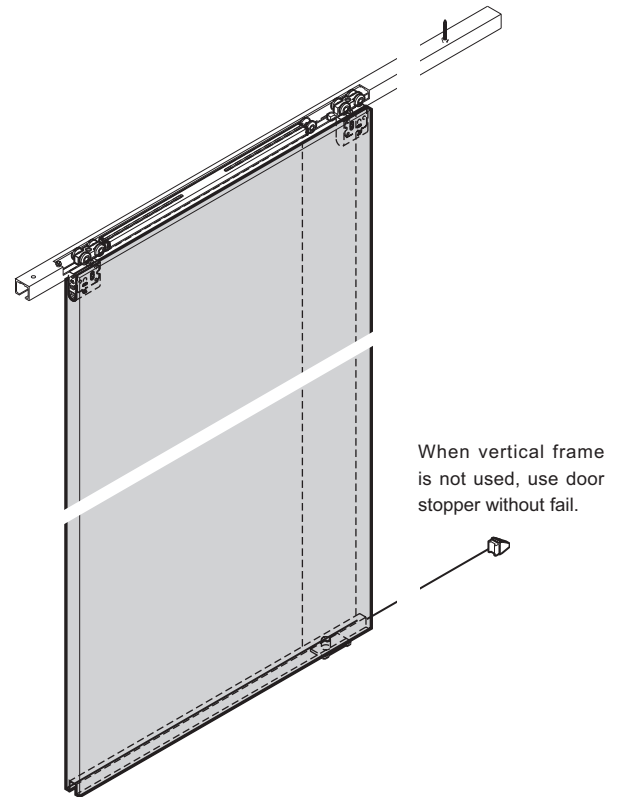

## FOR YOUR SAFETY AND CORRECT INSTALLATION

### Meaning of symbols

	<b>Warning Caution</b>		<b>Prohibited</b>		<b>Required</b>
--	------------------------	--	-------------------	--	-----------------









### **WARNING: If not followed, death or serious injury may result.**

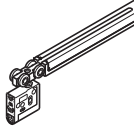

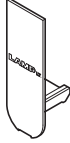

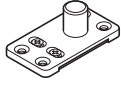
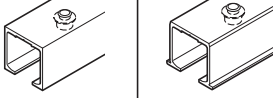
- This product should be installed by a qualified person in accordance with this manual. If it is not installed correctly, the door may fall and cause injury.
- Provide a frame that can withstand the weight and impact of opening and closing the door. Be sure to use the specified screws and tighten them securely. If the mounting strength is insufficient, the door may fall and cause injury.
- Do not use this product for any other purpose, or with doors that are outside the specifications of this manual.
- Do not disassemble or modify any parts other than those described in this document.

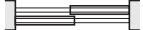

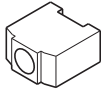

### **Caution: If not followed injury or damage may result.**

- Follow the specified dimensions, specifications, and alignment of the door and frame. Warping, tilting or twisting of the frame or door may cause failure.
- If cutting any parts, make sure to remove any burrs before installation. Also check the upper track for any left-over burrs or scraps and remove these.
- This product is a part for architectural fittings. After installation, please check the function and safety of the final product. Please inform the end user how to use the product safely.
- Make sure to check the screws for slack at regular intervals (one month from first usage, half a year, and then one time every year is recommended).

# COMPONENT PARTS

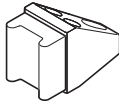
No	①	②	③	④	⑤	⑥	
Name	Soft Closer	Upper roller	Cover cap	Trigger, Jig	Floor guide	Upper track (surface mounted)	Upper track (recessed mount)
Item No.	FD30-WRH-DSC	FD30-WRH-N	FD30-WRH	FD25SP-30-TRG FD25SP-30-TRJ	FD30-HBG-LBR	FD30-TRM	FD30-TRH
Item	 Accessory screw: Pan head tapping screw 3.5×30 ..... 3 pcs	 Accessory screw: Pan head tapping screw 3.5×30 ..... 3 pcs		 Trigger Jig	 Accessory screw: Countersunk head tapping screw 3.5×30 ..... 4 pcs	 (various sizes) Hole pitch : 300 mm Pitch end : 30 mm Recommended screw : Countersunk head tapping screw 3.5×20	
Single sliding 	1 pc	1 pc	2 pcs	1 pc	1 pc	Use 1 (surface mounted or recessed)	
Double sliding 	2 pcs	2 pcs	4 pcs	2 pcs	2 pcs	Use 2 (surface mounted or recessed)	
In line sliding 	2 pcs	2 pcs	4 pcs	2 pcs	2 pcs	Use 2 (surface mounted or recessed)	

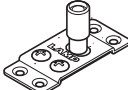
No	⑦
Name	Stopper
Item No.	FD30-HSB
Item	
Single sliding 	—
Double sliding 	—
In line sliding 	2 pcs

OPTIONAL PARTS	No	⑧	⑨	⑩	⑪
	Name	Door stopper (floor mount)	Recessed guide track under door	Floor guide (long shaft)	Spanner
	Item No.	FD30-HTKY	FD30-HBRT	FD30-HBGH	FD30-FSP
Item	 Accessory screw: Bind head tapping screw 4×30 ..... 3 pcs	 1000 mm / 1500 mm Hole pitch : 300 mm Pitch end : 30 mm Recommended screw: Countersunk head tapping screw 4×20	 Accessory screw: Pan head tapping screw (Stainless steel) 3.5×30 ..... 4 pcs	 Nominal designation 10 mm, 12 mm	

# INSTALLATION DRAWING (EXAMPLE)

Recommended screw : Philips flush tapping screw  
Note : Not provided.

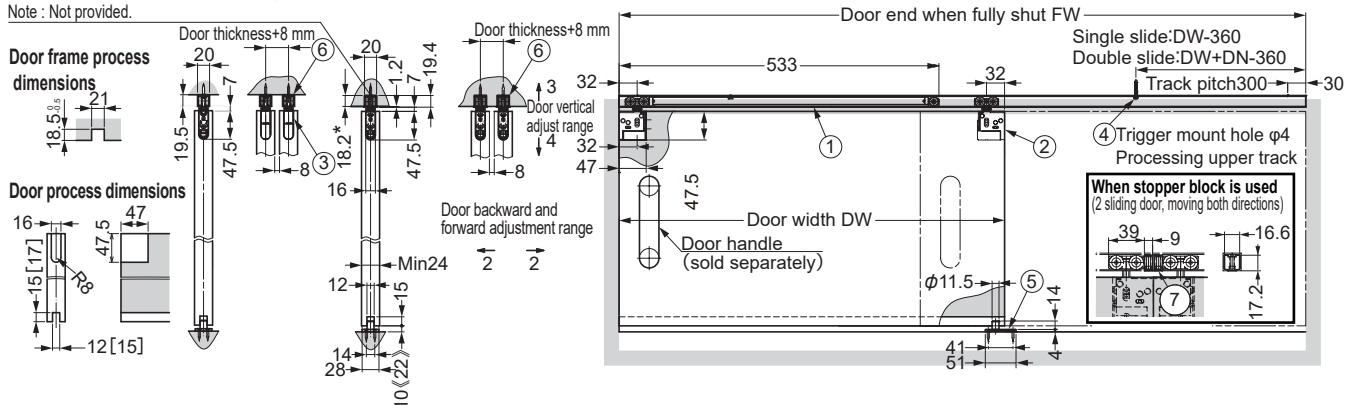

dimensions in [ ] : When recessed guide track (option) is used.  
( ) : When long shaft floor guide (option) is used.

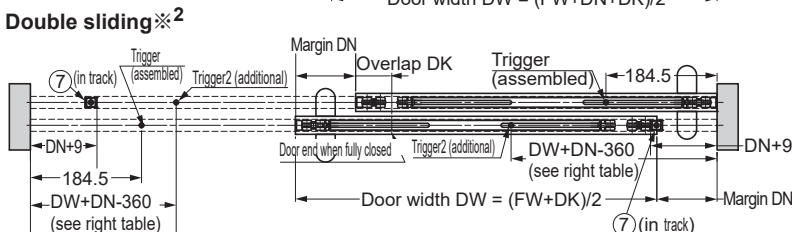
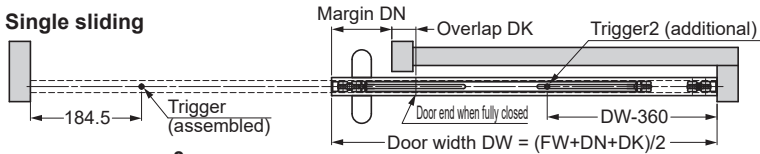

※<sup>2</sup> For Double sliding only.

INSTALLATION DIMENSIONS FOR TRIGGER 2

Please add the Margin DN to dimension for Trigger 2, if you are using a protruding handle.  
Example shown below.

DW	[Margin DN = 0 mm] Installation dimension for Trigger 2	Example [Margin DN = 70 mm] DW+DN-360 is the Installation dimension for Trigger 2
600	240	310
700	340	410
800	440	510
900	540	610
1000	640	710

# ASSEMBLY

## 1 Preparation and Installation

### 1. Cutting and Drilling Holes on Upper Track

#### Caution

- Do not cut trigger side (with sticker) of upper track.
- When cutting, reinforce the track to prevent deformation at the cut section.

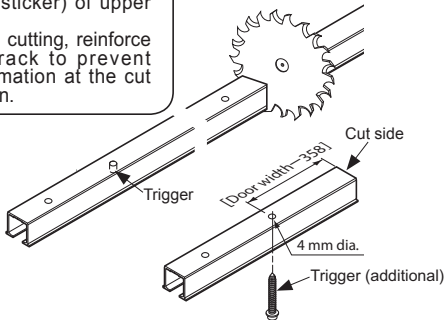

### 2. Preparation of Mounting Parts

- [1] Soft closer and upper roller:  
Separate main unit from casing.

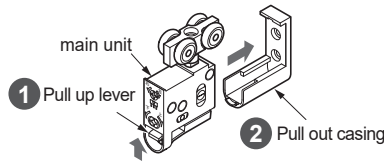

- [2] Loosen fixing screw on end catch.

### 3. Installing Casing

Fasten the casing firmly with attached screws.

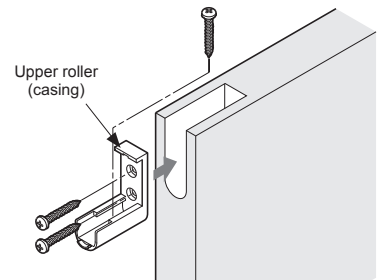

### 4. Verification before Installing Soft Closer

#### Caution

- Without verification the self closing feature may fail.

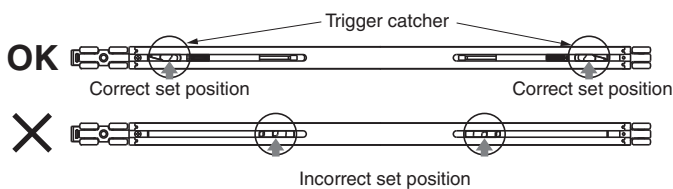

If the position is wrong, pull back the trigger catcher to the correct position using 6mm diameter round hard bar.

### 5. Inserting Parts into Upper Track

Assemble the parts in order of ① to ② with care of direction.

#### Caution

- Tape upper roller and upper track to prevent inserted parts from falling.
- Remove any dirt or aluminum chips from the track.

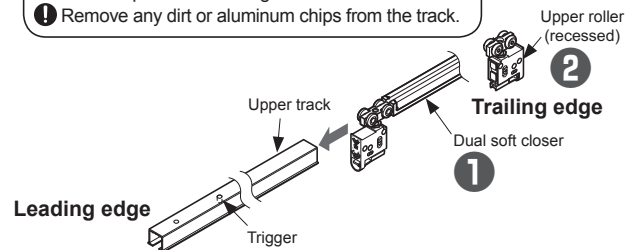

### 6. Fixing Upper Track

Recommended screw: countersunk head tapping screw 3.5 × 20

### 7. Fixing Additional Trigger

Fix trigger to the hole made during procedure 1 with the jig.

According to the "Installation Drawing", install the additional trigger into the  $\phi 4$  hole near the trailing edge using the provided trigger mount jig.

#### Caution

- Set the additional trigger vertically. Or, improper movement will result.

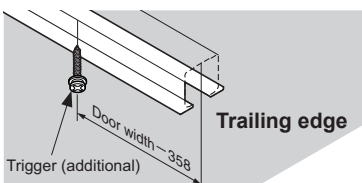

### Operation of trigger mounting jig

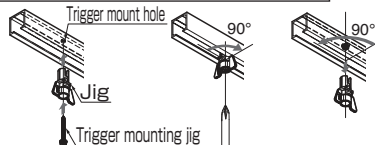

1. Align trigger and mounting jig with mount hole



2. Install trigger. 3. Remove the jig
- Incomplete screwing
  - Out of straight
  - Correct installation

### 8. Fixing Floor Guide

Install the floor guide so that it remains between the leading and trailing edges of the door when it is opened or closed.

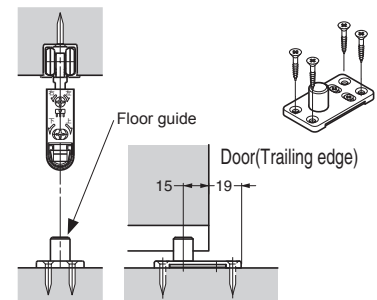

## 2 Hanging the Door and Adjustment

### 1. Bottom Part

Put a 10 mm support under the door. While holding the door, insert the floor guide into the groove under the door.

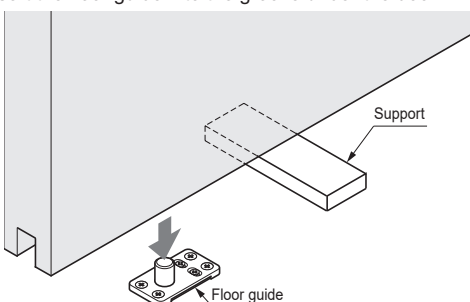

### 2. Top Part

Insert the upper roller into casing, until a "click" sound is heard.

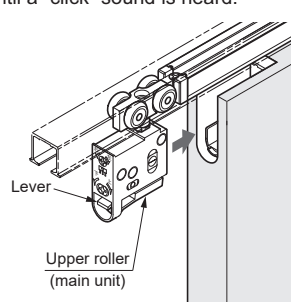

#### Caution

- Confirm that the upper roller is not dislocated from the casing, for both door sides.

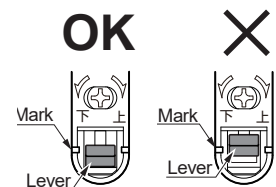

### 3. Verification of Sliding Door Closer Operation

- [1] Remove the support from under the door.
- [2] Close the door slowly and check that the soft closer works correctly. The soft closer is engaged approximately 100 mm at the leading edge before the door reaches its final position.
- [3] Please refer to the "Troubleshooting" section when the soft closer does not work correctly.

#### Caution

- Do not close the door with excessive force. It may cause damage to the soft close mechanism.

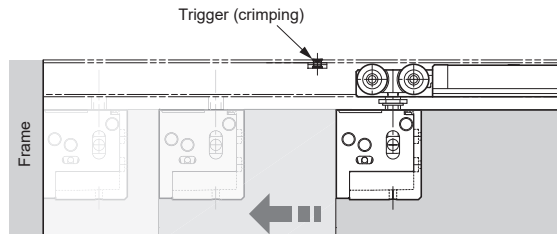

### 4. Adjusting the Door Position

Adjust the door so that it is parallel to the upper track with 6 - 13 mm of clearance between the door and floor.

#### Caution

- The adjustment of the door should be done with the jump prevention nut loosened.
- Do not turn adjustment screw beyond adjustment range.
- Do not use electric screw driver.

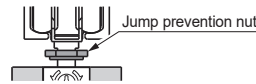

Vertical adjustment range: 7 mm

Depth adjustment range: 4 mm

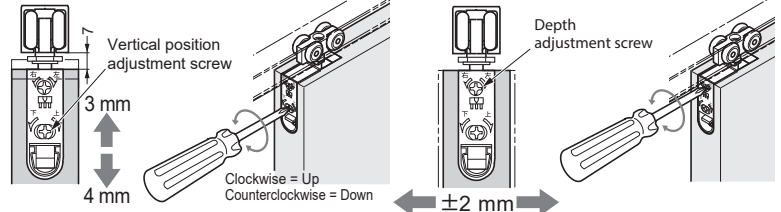

### 5. Adjusting Floor Guide: Adjustment Range 4 mm.

Slowly close and open the door. If the door does not move smoothly, it is necessary to make an adjustment to the floor guide and door.

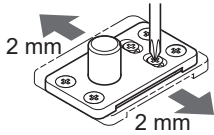

### 6. Fastening the Jump Prevention Nut

The jump prevention nut is on the hanger bolt of the upper roller. Tighten the nut with the optional spanner ① or 12 mm spanner until it contacts the soft closer.

#### Caution

- Be sure to tighten the nut to prevent damaging parts.

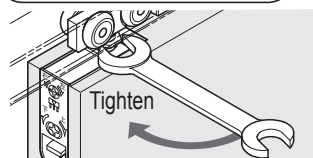

When vertical frame is not used, use door stopper without fail.

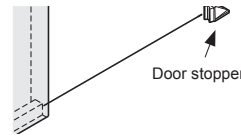

### How to Remove Door

- [1] Use a 10 mm support under the door.
- [2] Pull out the upper roller main unit from the door while raising the lever.

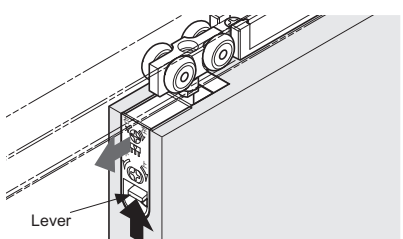

### PERIODICAL INSPECTION

- Clean the inside of the track.
- Check the upper and lower space of the door. If necessary, correct the space.

## TROUBLESHOOTING

Trouble	Checkpoint	Solution
Door stops during soft closing	Check if door bottom contacts with floor or floor guide.	Verify that track mounting screws are not loosened. Then, adjust door height such that the clearance between the door bottom and floor is 6 - 13 mm.
	Check if the upper track is set horizontally.	Using a level gauge, reset the upper track horizontally.
	Check if mohair seal is installed.	Reduce the friction between the mohair and door.
The door doesn't close softly.	Check if trigger is installed.	Install trigger to specific position.
	Check if door is closed by excessive force.	Do not close door by excessive force as it may damage the soft closer.
Abnormal noise during operation	The position of the trigger catcher in page 3 section ①-4 may become dislocated (It is hidden as installed in upper track.)	Remove the door and the upper track, then check the status of the trigger catcher in section ①-4.
	Check if door bottom contacts with floor or floor guide.	Verify that track mounting screws are not loosened. Then, adjust door height such that the clearance between the door bottom and floor is 6 - 13 mm.
	Check if door touches adjacent parts.	Adjust the door depth position to avoid contact with other objects or adjust the position of floor guide.
	Check track rollers for aluminum dust.	Remove the track, then pull out and clean the roller.
Heavy door operation	Check the track mounting screws for looseness.	Retighten the screw to free the roller.
	Check if door touches adjacent parts.	Adjust the door depth position to avoid contact with other objects or adjust the position of floor guide.
	Check if door bottom contacts with floor or floor guide.	Verify that track mounting screws are not loosened. Then, adjust door height such that the clearance between the door bottom and floor is 6 - 13 mm.
Door does not move.	Check the track retaining screws for looseness.	Retighten screws to free the roller.
Door starts to move	Check if the upper track is set horizontally.	Using a level gauge, reset the upper track horizontally.

**SUGATSUNE KOGYO CO.,LTD**  
Tokyo, JAPAN  
Phone: +81 (0)3 3866 2260 E-mail:export@sugatsune.co.jp

**SUGATSUNE KOGYO (UK) LTD**  
Reading, UK  
Phone: +44 118 9272 955 E-mail:sales@sugatsune.co.uk

**SUGATSUNE SHANGHAI Co., LTD**  
Shanghai, CHINA  
Phone: +86 21 3632 1858 E-mail:lamp@sugatsune.com.cn

**Guangzhou, CHINA**  
Phone: +86 20 6639 3552 E-mail:lamp@sugatsune.com.cn

**SUGATSUNE AMERICA, INC**  
California, USA  
Phone: +1 310 329 6373 E-mail:sales@sugatsune.com

**Chicago, USA**  
Phone: +1 312 461 1081 E-mail:chicagoshowroom@sugatsune.com.

**SUGATSUNE EUROPE GmbH**  
Düsseldorf, GERMANY  
Phone: +49 211 53812900 E-mail:sales@sugatsune.eu

**SUGATSUNE KOGYO INDIA PRIVATE LIMITED**  
Mumbai, INDIA  
Phone: +91 22 28314490/91 E-mail:sales@sugatsune.in

**SUGATSUNE CANADA, INC.**  
Phone: +1 514 312 5267 E-mail:support@sugatsune.ca