

LAMP® FD30-H SLIDING DOOR SYSTEM Installation Manual

Recessed Mount Roller, One-Way Soft Close

Part No.FD30HCP

Thank you for selecting our product. Before starting installation, please read this manual thoroughly to ensure correct installation. Please keep this manual at hand for future reference.

ABOUT THE PRODUCT

- This is a parts set for sliding door system for residence.
- The door closes in 2 soft motion steps.
- Easy door installation and adjustment.

SPECIFICATIONS

Max. Door height	2400 mm
Door width	510 mm – 1000 mm
Min. Door thickness	24 mm
Max. Door weight	30 kg ※ ¹
Vertical adjustment	3 mm upward, 4 mm downward
Depth adjustment	±2 mm

- The closing speed of the soft closing type door may change due to ambient temperature, operating method or installation quality.
- Recommended ambient temperature range is 5 to 40 °C .

※¹ If a light weight door is applied, you may feel the resistance of the soft closer when opening the door.

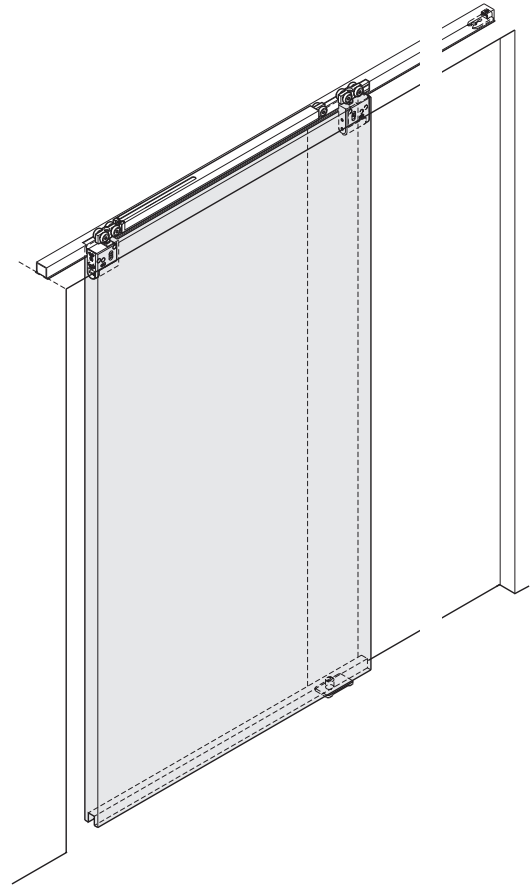

FOR YOUR SAFETY AND CORRECT INSTALLATION

Meaning of symbols

 Warning Caution	 Prohibited	 Required
--	---	---



WARNING: If not followed, death or serious injury may result.



- ❗ This product should be installed by a qualified person in accordance with this manual. If it is not installed correctly, the door may fall and cause injury.
- ❗ Provide a frame that can withstand the weight and impact of opening and closing the door. Be sure to use the specified screws and tighten them securely. If the mounting strength is insufficient, the door may fall and cause injury.
- ⊘ Do not use this product for any other purpose, or with doors that are outside the specifications of this manual.
- ⊘ Do not disassemble or modify any parts other than those described in this document.

Caution: If not followed injury or damage may result.

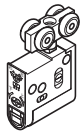
- ❗ Follow the specified dimensions, specifications, and alignment of the door and frame. Warping, tilting or twisting of the frame or door may cause failure.
- ❗ If cutting any parts, make sure to remove any burrs before installation. Also check the upper track for any left-over burrs or scraps and remove these.
- ❗ This product is a part for architectural fittings. After installation, please check the function and safety of the final product. Please inform the end user how to use the product safely.
- ❗ Make sure to check the screws for slack at regular intervals (one month from first usage, half a year, and then one time every year is recommended).

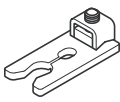
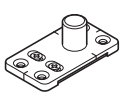
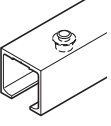
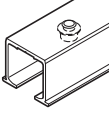
COMPONENT PARTS

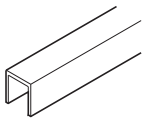
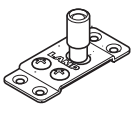
No.	①	②	③	④	⑤	⑥	
Name	Soft closer	Upper roller	Cover cap	End catch	Floor guide	Upper track (surface mount)	Upper track (recessed mount)
Part No.	FD30-WRH-SC	FD30-WRH	FD30-WRH-CP	FD30-HTST-DB	FD30-HBG-LBR	FD30-TRM	FD30-TRH
Parts			 Thickness:2 mm			 Hole pitch : 300 mm Pitch end : 30 mm	 Hole pitch : 300 mm Pitch end : 30 mm
Accessories	Pan head tapping screws 3.5×30 3 pcs	Pan head tapping screws 3.5×30 3 pcs	—	—	Countersunk head tapping screws 3.5×30 ·· 4 pcs	—	—
Remarks	—	—	—	—	—	Recommended screw : Countersunk head tapping screw 3.5×20	

OPTIONAL PARTS	No.	⑦	⑧	⑨
	Name	Door guide track	Floor guide (long shaft)	Spanner
	Part No.	FD30-HBRT	FD30-HBGH	FD30-FSP
Parts	 Hole pitch : 250 mm Pitch end : 30 mm	 Countersunk head tapping screws 3.5×30 ·· 4 pcs	 Nominal designation 10 mm, 12 mm	

INSTALLATION DRAWING (EXAMPLE)

(This describes installation of a single sliding door.)

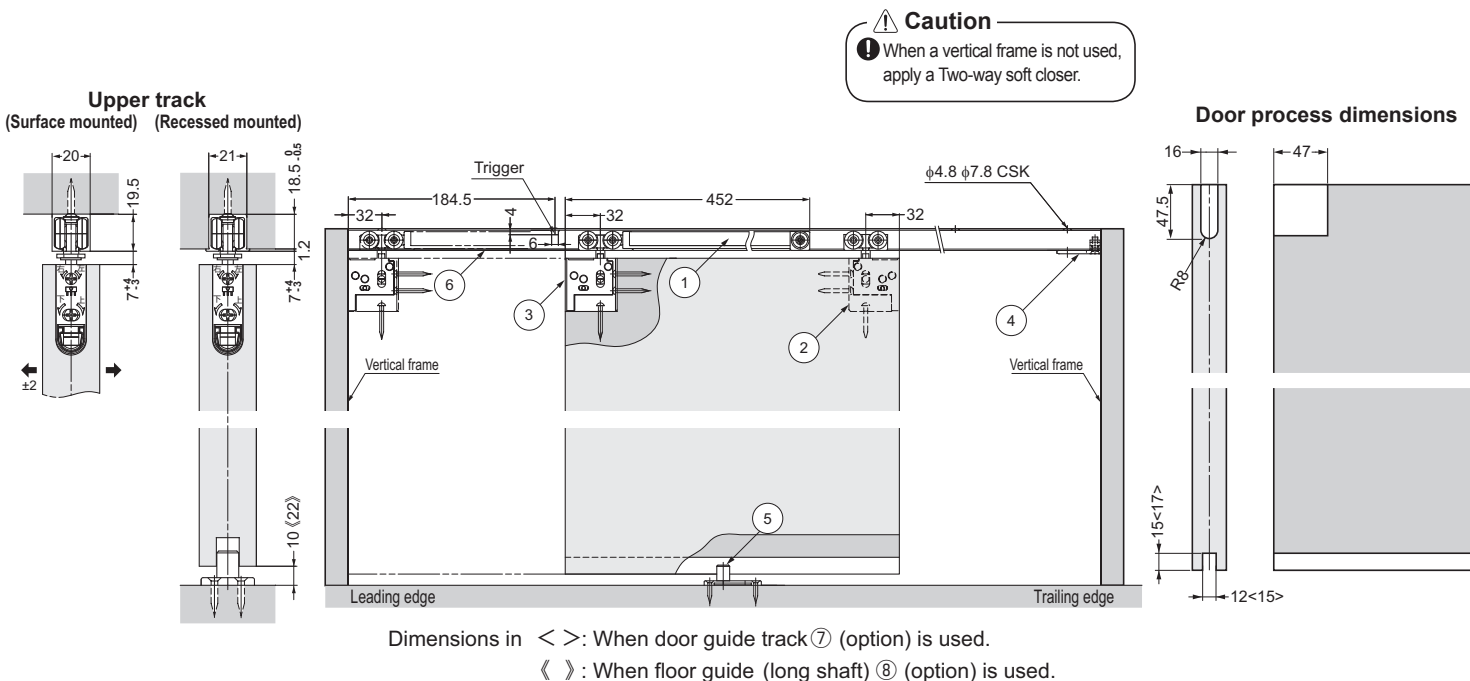

1 Preparation and Installation

1. Cutting and Drilling Holes on Upper Track

⚠ Caution

- Do not cut trigger side (with sticker) of upper track.
- When cutting, reinforce the track to prevent deformation at the cut section.

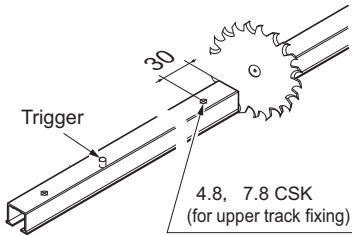

2. Preparation of Mounting Parts

- [1] Soft closer and upper roller:
Separate main unit from casing.

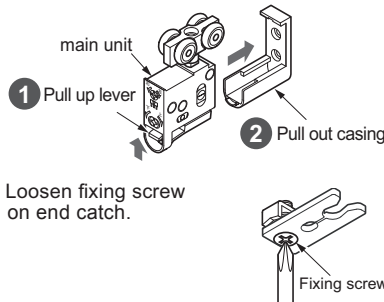

- [2] Loosen fixing screw on end catch.

3. Installing Casing

Fasten upper roller firmly with attached screws.

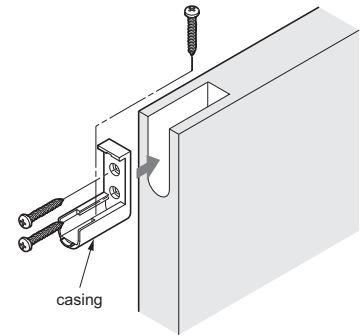

4. Verification before Installing Soft Closer

⚠ Caution

- Without verification the self closing feature may fail.

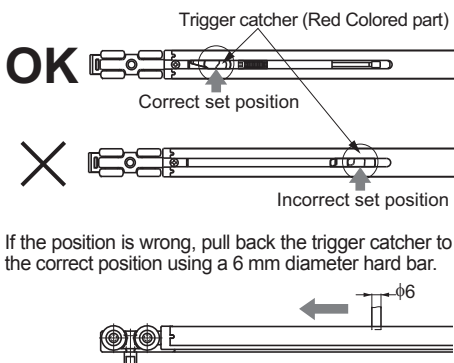

5. Inserting Parts into Upper Track

Assemble the parts in order from 1 to 3 with care of direction.

⚠ Caution

- Tape upper roller and upper track to prevent inserted parts from falling.
- Remove any dirt or aluminum chips from the track.

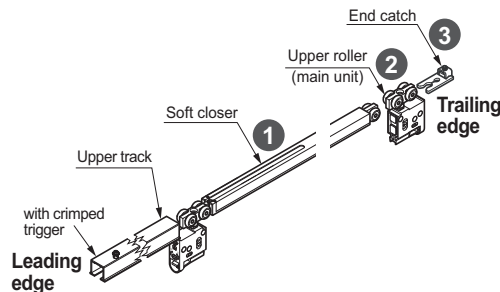

6. Fixing Upper Track

Recommended screw:
Counter sunk head tapping screw 3.5 × 20

7. Fixing floor guide

Install the floor guide so that it remains between the leading and trailing edges of the door when it is opened or closed.

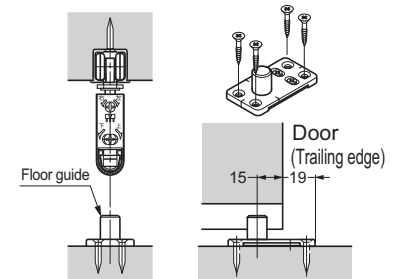

2 Hanging the Door and Adjustment

1. Bottom Part

Put a 10 mm support under the door. While holding the door, insert the floor guide into the groove under the door.

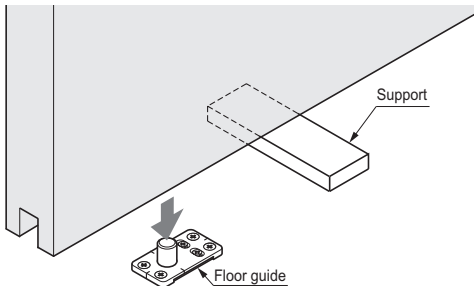

2. Top Part

Insert the upper roller into casing, until a "click" sound is heard.

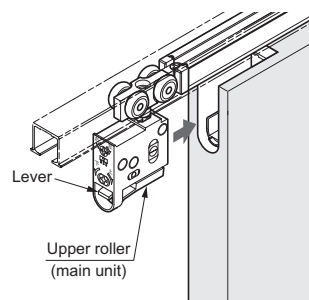

⚠ Caution

- Confirm that the upper roller is not dislocated from the casing, for both door sides.

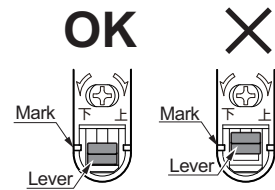

3. Verification of Sliding Door Closer Operation

- Remove the 10 mm support from under the door.
- Close the door slowly and check that the soft closer works correctly. The soft closer is engaged approximately 100 mm at the leading edge before the door reaches its final position.
- Please refer to the "Troubleshooting" section when the soft closer does not work correctly.

⚠ Caution

- Do not close the door with excessive force. It may cause damage to the soft close mechanism.

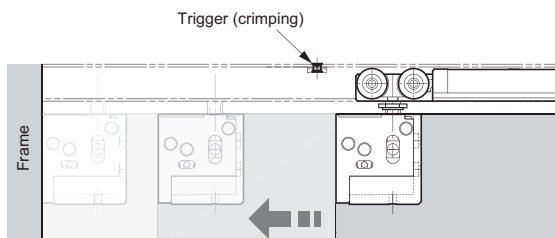

4. Adjusting the Door Position

Adjust the door so that it is parallel to the upper track with 6 - 13 mm of clearance between the door and floor.

⚠ Caution

- The adjustment of the door should be done with the jump prevention nut loosened.

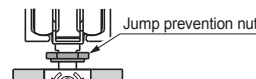

- Do not turn adjustment screw beyond adjustment range.
- Do not use electric screw driver.



Vertical adjustment range: 7 mm

Depth adjustment range: 4 mm

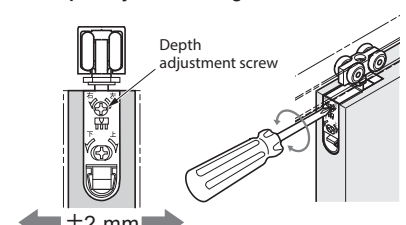
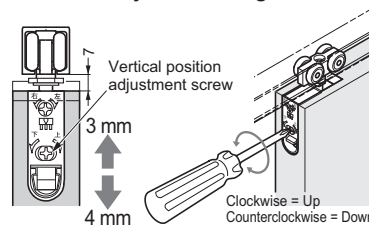

5. Adjusting Floor Guide: Adjustment Range 4 mm.

Slowly close and open the door. If the door does not move smoothly, it is necessary to make an adjustment to the floor guide and door.

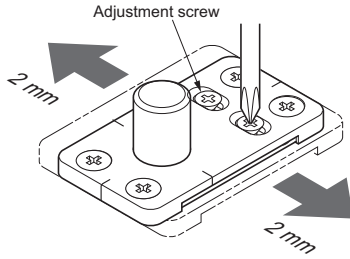

6. Fixing the End Catch Position

Fix the end catch 5 mm from the position where door stops.

Adjust the position of the end catch where it catches the hanger bolt of the roller when the door is stopped by the frame or door stopper.

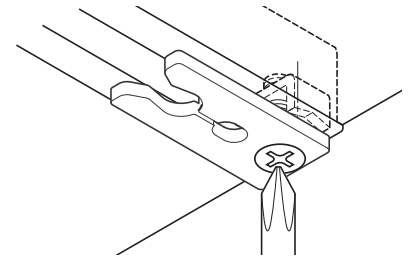
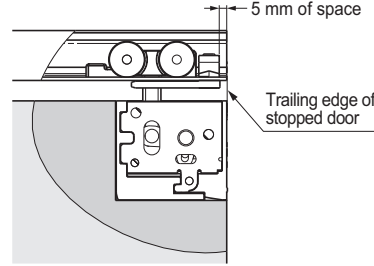

7. Fastening the Jump Prevention Nut

The jump prevention nut is on the hanger bolt of the upper roller. Tighten the nut with the optional spanner ⑨ or 12 mm spanner until it contacts the soft closer.

Caution
Be sure to tighten the nut to prevent damaging parts.

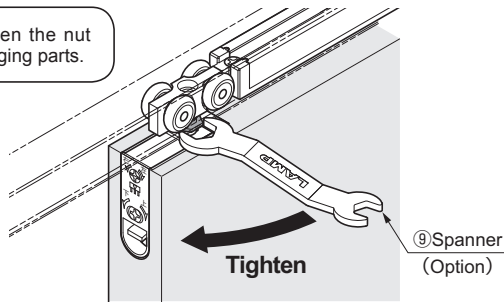

How to Remove Door

- [1] Use a 10 mm support under the door.
- [2] Pull out the upper roller main unit from the door while raising the lever.

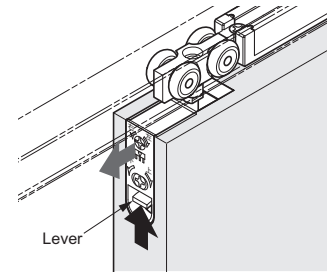

PERIODICAL INSPECTION

- Clean the inside of track.
- Check the upper and lower space of the door. If necessary, correct the space..

■ TROUBLESHOOTING

Trouble	Checkpoint	Solution
Door stops during soft closing	Check if door bottom contacts the floor or floor guide.	Verify that the track mounting screws are not loosened. Then, adjust the door height such that the clearance between the door bottom and floor is 6 - 13 mm.
	Check if the upper track is set horizontally.	Using a level gauge, reset the upper track horizontally.
	Check if mohair seal is installed.	Reduce the friction between the mohair seal and door.
No soft closing	Check if trigger is installed.	Install trigger to specified position.
	Check if door is closed by excessive force. The position of the trigger catcher in page 3 section 4 may become dislocated. (It is hidden as installed in upper track.)	Do not close door by excessive force as it may damage the soft closer. Remove the door and the upper track, then check the status of the trigger catcher in section 4.
Abnormal noise during operation	Check if door bottom contacts the floor or floor guide.	Verify that the track mounting screws are not loosened. Then, adjust the door height such that the clearance between the door bottom and floor is 6 - 13 mm.
	Check if door touches adjacent parts.	Adjust the door depth position to avoid contact with other objects or adjust the position of floor guide.
	Check track rollers for aluminum dust.	Remove the track, then pull out and clean the roller.
	Check the track mounting screws for looseness.	Retighten the screws to free the roller.
Heavy door operation	Check if door bottom contacts with floor.	Verify that the track mounting screws are not loosened. Then, adjust the door height such that the clearance between the door bottom and floor is 6 - 13 mm.
	Check if door touches adjacent parts.	Adjust the door depth position to avoid contact with other objects or adjust the position of floor guide.
Door does not move.	Check the track retaining screws for looseness.	Retighten screws to free the roller.
Door starts to move.	Check if the upper track is set horizontally.	Using a level gauge, reset the upper track horizontally.
End catch does not work properly.	Check if roller is installed correctly.	If a roller for Two-way soft closer (FD35EV-WRH-N) is installed by mistake, jump prevention nut on the roller interferes with the end catch. Replace it with correct roller.