

Installation Manual

FD30-H SLIDING DOOR SYSTEM

Side-Mount Roller Standard Sliding

LAMP®

Part No.
FD30-HUP

Thank you for selecting our product. Before installation, please read this manual thoroughly to ensure correct installation. Please keep this manual at hand for future reference.

ABOUT THE PRODUCT

- This product is parts set for sliding door system for indoor use.
- Easy door installation and adjustment.

SPECIFICATIONS

Max. Door width	1000 mm
Max. Door height	2400 mm
Min. Door thickness	28 mm
Max. Door weight	30 kg / door
Vertical adjustment	± 4 mm

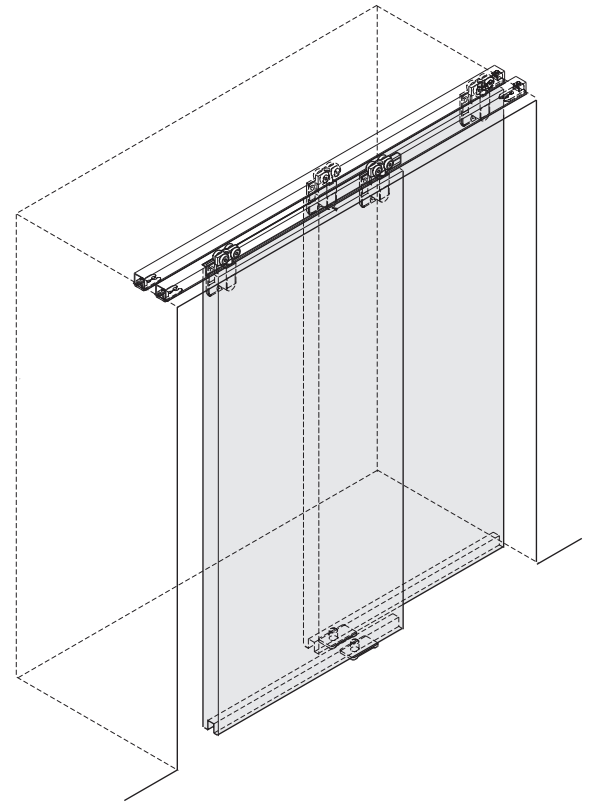

FOR YOUR SAFETY AND CORRECT INSTALLATION



WARNING: If not followed, death or serious injury may result.



- This product should be installed by a qualified person in accordance with this manual. If it is not installed correctly, the door may fall and cause injury.
- Provide a frame that can withstand the weight and impact of opening and closing the door. Be sure to use the specified screws and tighten them securely. If the mounting strength is insufficient, the door may fall and cause injury.





- Do not use this product for any other purpose, or with doors that are outside the specifications of this manual.
- Do not disassemble or modify any parts other than those described in this document.

Caution: If not followed, injury or damage may result.

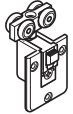
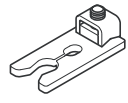
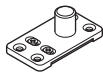
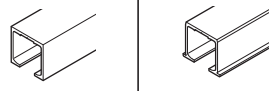

- Follow the specified dimensions, specifications, and alignment of the door and frame. Warping, tilting or twisting of the frame or door may cause failure.
- If cutting any parts, make sure to remove any burrs before installation. Also check the upper track for any left-over burrs or scraps and remove these.
- This product is a part for architectural fittings. After installation, please check the function and safety of the final product. Please inform the end user how to use the product safely.
- Make sure to check the screws for slack at regular intervals (one month from first usage, half a year, and then one time every year is recommended).
- Install the product with 2 people (in the case of 1 person, there is a risk of damaging components).

COMPONENT PARTS

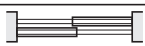
No.	①	②	③	④	
Name	Side mount roller	End catch	Floor guide (with roller)	Upper track (Surface mount)	Upper track (Recessed mount)
Item No.	FD30-WRU	FD30-HTST	FD30-HBG	FD30-TRM	FD30-TRH
Item	 Accessory screw: Bind head tapping screw 3.5x30 3pcs		 Accessory screw: Countersunk head tapping screw 3.5x30 4pcs	 (various sizes) Hole pitch : 300 mm Pitch end : 30 mm Recommended screw : Countersunk head tapping screw 3.5x20	
Single sliding	 2pcs	2pcs	1pc	Use 1 (surface mount or recessed)	
Double sliding	 4pcs	4pcs	2pcs	Use 2 (surface mount or recessed)	

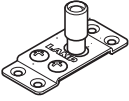
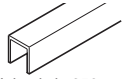
OPTIONAL PARTS	No.	⑤	⑥
	Name	Floor guide (long shaft)	Recessed guide track under door
	Item No.	FD30-HBGH	FD30-HBRT
Item	 Accessory screw: Pan head tapping screw (Stainless steel) 3.5x30 4pcs	 (various sizes) Hole pitch :250 mm Pitch end :30 mm Recommended screw: Countersunk head tapping screw 4x20	

INSTALLATION DRAWING (EXAMPLE)

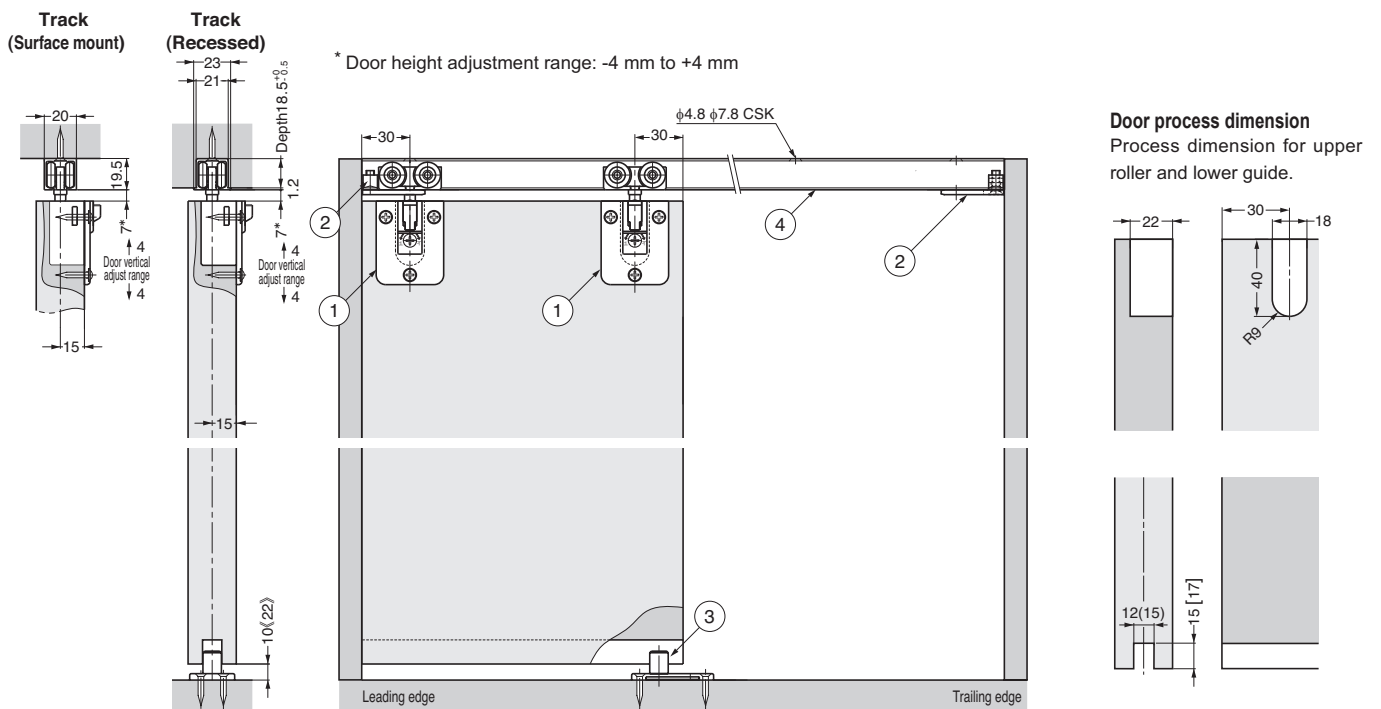

Dimension in { } : When long shaft floor guide (option) is used.
[] : When recessed guide track under door (option) is used.

ASSEMBLY

1 Preparation and Installation

1. Cutting track

Cut the track to required length.

△ When cutting, use reinforcer for the track to prevent deformation at cut section.

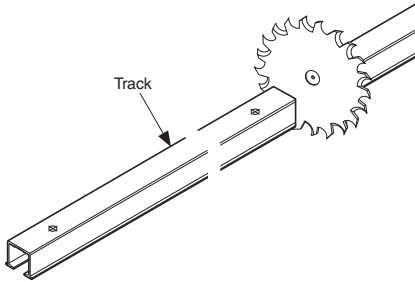

2. Preparation of mounting parts

Roller: Pull up lever to separate main unit from casing.

Loosen fixing screw on end catch.

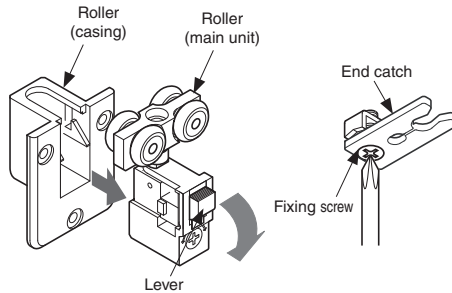

3. Installing casing

Firmly insert upper roller casing into the place as shown, fix it with attached screws.

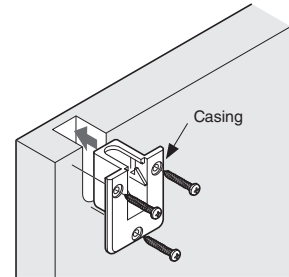

4. Assembly of parts

Assemble parts, in order of end catch, roller, and end catch, taking care for part direction.

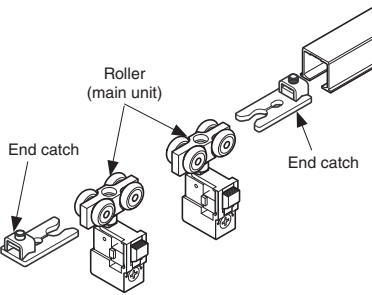

5. Floor guide

Install the floor guide so that it remains between the leading and trailing edges of the door when it is opened or closed.

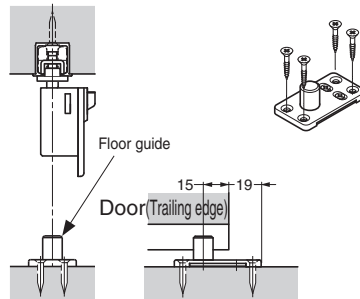

2 Hanging Door and Adjustment

1. Door installation (bottom)

Put 10 mm support under the door.

Insert the floor guide in the groove, and then hang the door.

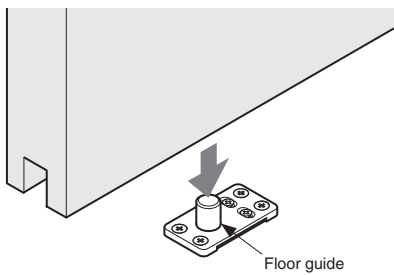

2. Fixing door (top)

Insert roller main unit into the casing installed on door until "click" sound is heard.

△ Ensure that roller main unit is securely attached to the casing.

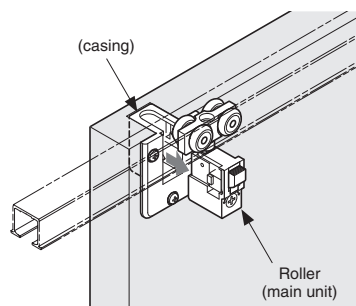

3. Door vertical adjustment (8 mm)

Adjust door such that door is parallel to upper track with 10 mm distance between door and floor.

- ⊘ Do not turn adjustment screw more than adjustment range.
- ⊘ To avoid damage on the adjustment screw, do not use electric screw driver.

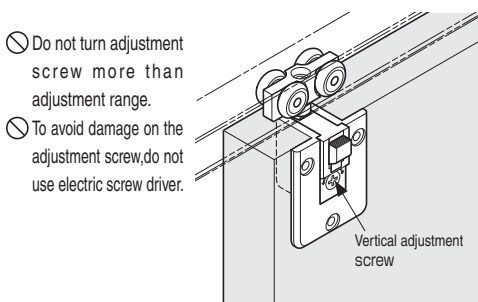

4. Adjusting Floor guide: adjust range is 4 mm.

Slowly close and open the door. If door is not moved smoothly, it is necessary to make forward / backward adjustment for Floor guide and door.

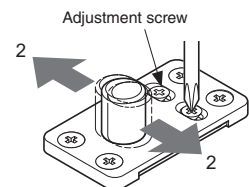

5. Fixing End catch position

Fix end catch at the position where the center of End stopper is 30 mm from the vertical frame. Then slowly moving the door to close. If necessary, adjust upper stopper position.

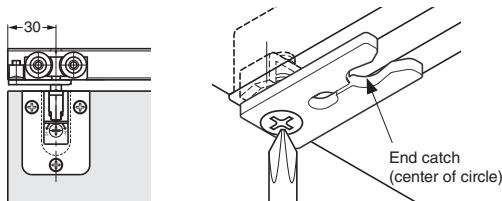

When removing the door

Use a 10 mm support under the door. Then pull out the roller main unit from the door while raising the lever.

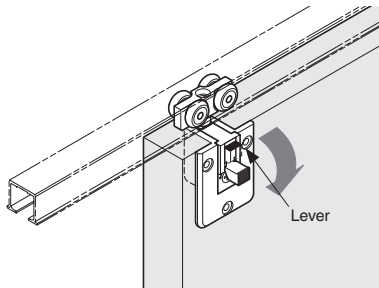

PERIODICAL INSPECTION

- Clean the inside of the track.
- Check the upper and lower space of the door. If necessary, correct the space.

TROUBLESHOOTING

Trouble	Checkpoint	Solution
Abnormal noise during operation	Check if door bottom contacts the floor or floor guide.	Verify that the track mounting screws are not loosened. Then, adjust the door height such that the clearance between the door bottom and floor is 6 - 14 mm.
	Check if door touches adjacent parts.	Adjust the position of floor guide to avoid contact with other objects.
	Check track rollers for aluminum dust.	Remove the track and pull out the roller. Then, clean the roller.
	Check the track mounting screws for looseness.	Retighten the screws to free the roller.
Heavy door operation	Check if door bottom contacts the floor or floor guide.	Verify that the track mounting screws are not loosened. Then, adjust the door height such that the clearance between the door bottom and floor is 6 - 14 mm.
	Check if door touches adjacent parts.	Adjust the position of floor guide to avoid contact with other objects.
Door does not move.	Check the track mounting screws for looseness.	Retighten the screws to free the roller.
Door starts to move.	Check if the upper track is set horizontally.	Using a level gauge, reset the upper track horizontally.

SUGATSUNE KOGYO CO., LTD.

Tokyo, JAPAN
Phone: +81 3 3866 2260
E-mail: export@sugatsune.co.jp

SUGATSUNE KOGYO (UK) LIMITED

Reading, UK
Phone: +44 1189 272 955
E-mail: sales@sugatsune.co.uk

SUGATSUNE EUROPE GmbH

Düsseldorf, GERMANY
Phone: +49 211 53812 900
E-mail: sales@sugatsune.eu

SUGATSUNE AMERICA, INC.

California, USA
Phone: +1 310 329 6373
E-mail: sales@sugatsune.com

Chicago, USA

Phone: +1 630 317 7072
E-mail: sales@sugatsune.com

SUGATSUNE CANADA, INC.

Montreal, CANADA
Phone: +1 514 312 5267
E-mail: support@sugatsune.ca

SUGATSUNE SHANGHAI CO., LTD.

Shanghai, CHINA
Phone: +86 21 3632 1858
E-mail: lamp@sugatsune.com.cn

Guangzhou, CHINA

Phone: +86 20 6639 3554
E-mail: lamp@sugatsune.com.cn

SUGATSUNE KOREA CO., LTD.

Incheon, KOREA
Phone: +82 32 220 0603
E-mail: sales@sugatsune-korea.co.kr

SUGATSUNE KOGYO INDIA

PRIVATE LIMITED
Mumbai, INDIA
Phone: +91 9867299597
E-mail: sales@sugatsune.in

Delhi, INDIA

Phone: +91 9867299597
+91 11 45093636

E-mail: sales@sugatsune.in