

LAMP® ALT-2V-220 POCKET DOOR HARDWARE (INSET) Installation Manual

Thank you for selecting our product. Before starting installation, please read this manual thoroughly to ensure correct installation. Please keep this manual at hand for future reference.

ABOUT THIS PRODUCT

- This product is parts set for installation of pocket door for cabinets.
- The door is stored inside the cabinet.

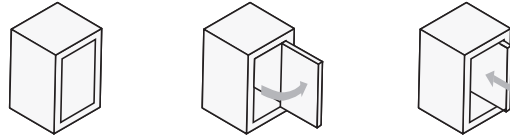

SPECIFICATION

Type	S	M	L	LL
Rail QTY	2	3	3	4
Max. Door width	Max. 560 mm	Max. 560 mm	Max. 560 mm	Max. 600 mm
Max. Door height	820 - 1060 mm	1240 - 1500 mm	1640 - 1840 mm	1980 - 2300 mm
Max. Door thickness	18 - 30 mm (18 - 20 mm when using 230-C26/OT)			
Max. Door weight	Max. 5Kg	Max. 6Kg	Max. 8Kg	Max. 10Kg

Part number guide

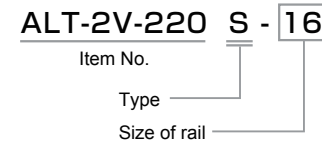

FOR YOUR SAFE WORK AND CORRECT INSTALLATION

Meaning of symbols



Caution If these cautions are not followed, it may result in injury or damage.

- ❗ It is necessary to manufacture the cabinet with sufficient strength so it endures the weight of the door and impact shocks upon opening/closing the door. Also make sure to only use the designated screws and to fasten them firmly. A cabinet with poor strength or loose screws might result in the door falling and causing injury.
- ❗ Make sure to follow the designated measurements, specifications, and horizontal/vertical angles. Make sure that the cabinet is not warped, since it may affect the movement of the door.
- ❗ Position the handle so that the hand holding the handle does not strike the side board.
- ❗ When moving the cabinet, remove the door and re-assemble it at the site.
- ❗ This (sliding door system) is a part for furniture fittings. After installation, make sure to test the finished product thoroughly to ensure that it is well-functioning and safe.
- ❗ Make sure to check the screws for slack at regular intervals (one month from first usage, half year and then one time every year is recommended).

About door operation

- ⚠ Inform cabinet users of the following precautions.
- ⚠ Do not try to open the door more than 93°.
- ❗ Do not try to close the door before pulling out fully. It will damage the hinges.
- ❗ To prevent injuries, ensure that there is enough space around the handle.

COMPONENT PARTS

Type	Rail ※ AL127C-** (**:Rail size)	Connecting plate	Concealed hinge ※2 H230-C26/OT	Mounting plate ALT-MP	AL127 Catch	Parts set				
						Roller	Roller bracket	Insert nut S.C-107-13	Slider	Stopper
S	2	ALT55-S: 1	2	2	1	2	A: 1 B: 1	2	2	2
M	3	ALT55-M: 1	3	3	2	2	A: 1 B: 1	2	2	3
L	3	ALT55-L: 1	3	3	2	2	A: 1 B: 1	2	2	3
LL	4	ALT55-LL: 1	4	4	2	2	A: 1 B: 1	2	2	4

SCREWS AND TOOL SUPPLIED

Accessory screws/Type	S	M	L	LL
① Cross recessed pan head screw M4 x 6	4	6	6	8
⑫ Hexagon socket head frange screw M4 x 6	4	6	6	8
⑬ Cross recessed bind head tapping screw 3.5 x 15	14	21	21	28
⑭ Cross recessed raised countersunk head tapping screw 3.5 x 15	4	6	6	8
⑮ Cross recessed bind head tapping screw 4 x 15	6	6	6	6
⑯ Hexagon socket screw keys	1	1	1	1

※ Rail size (inches) : 16, 19, 22, 24, 28

CABINET / DOOR WIDTH DIMENSIONS

The dimensions written within the brackets () apply when used with the concealed hinge 230-C26/OT. To make installation as well as maintenance possible make sure that the middle board can be removed.

Side view

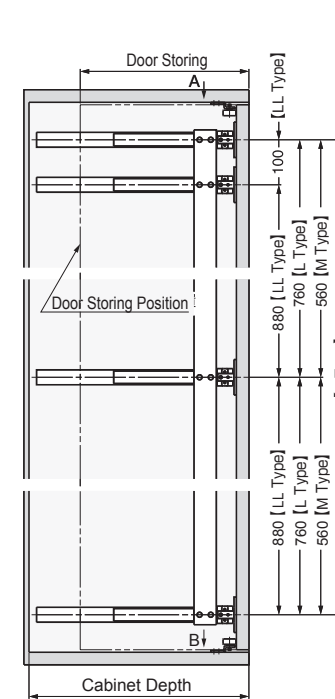

Front view

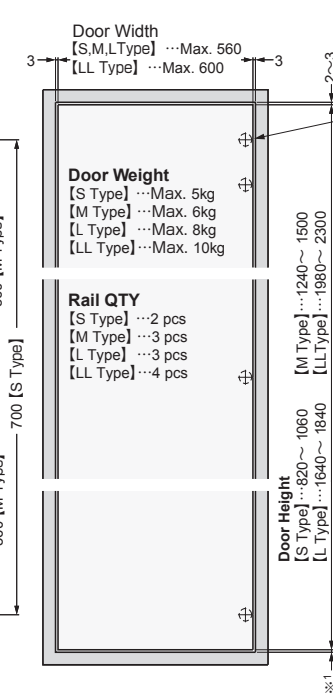

Door Processing

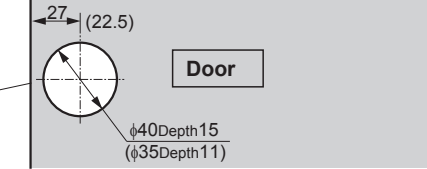

Arrow A

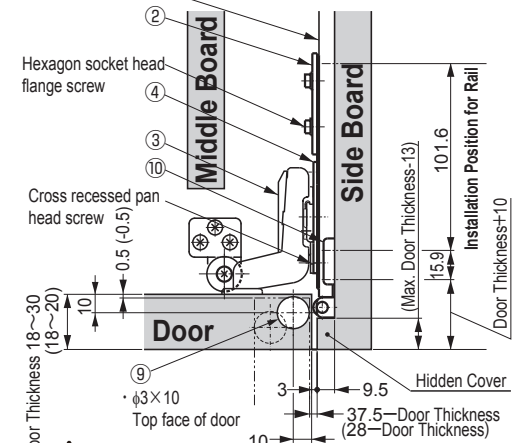

Caution
❗ Make middle board removable for maintenance.

Rail Size	Door Storing	Cabinet Depth
16	269+Door Thickness (270+Door Thickness)	412+ Door Thickness
19	345+Door Thickness (346+Door Thickness)	488+ Door Thickness
22	421+Door Thickness (422+Door Thickness)	564+ Door Thickness
24	472+Door Thickness (473+Door Thickness)	615+ Door Thickness
28	574+Door Thickness (575+Door Thickness)	717+ Door Thickness

Caution

- Be sure to mount rails parallel to each other.
- Attach the catch to the front end of the lower two rails as shown below. (As for ALT-2V-220S, the lowest rail only.)

Catch (AL-127-CH)

- This part catches the door at pulled out position.
- Attach the catch to the front end of rail. See INSTALLATION PROCEDURE 8 for detail.

※1 Arrow B (for Insert nut)

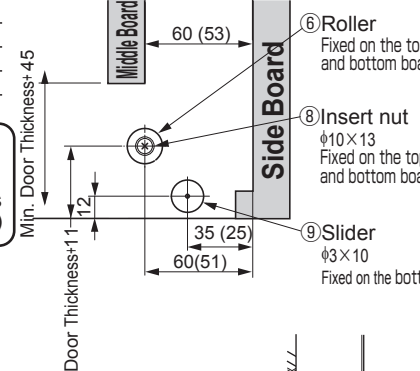

※2 Arrow B (for Roller bracket)

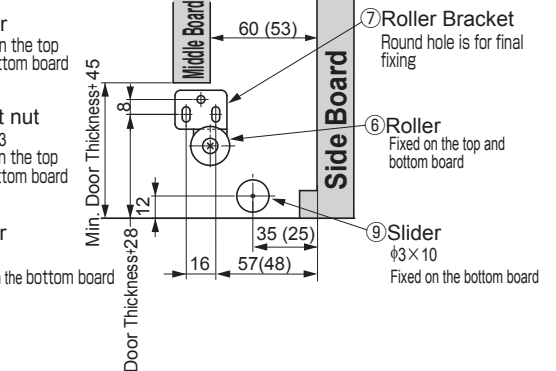

OPTIONAL PARTS

Bracket (side mount) ALT-BR

- This is a side mount bracket, designed to be used for applications where floor mounting is not possible.
- The bracket is non-handed.
- Can support thick doors since it is mounted to the roller on two places.

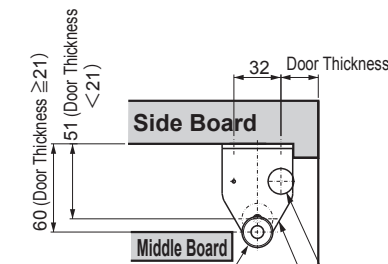
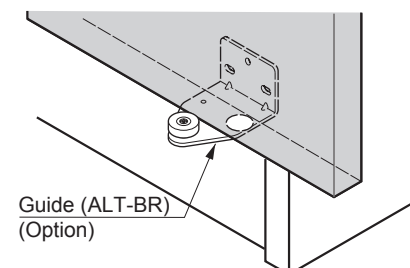

Section C-C

Mounting of slider
Above drawing shows the case of mounting on the right side board. In case of left side board, mount the slider in the left hole.

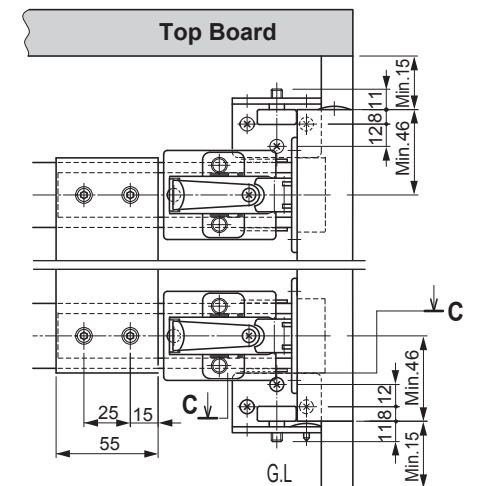

Dimensions when using Side mount bracket

INSTALLATION PROCEDURE

1 Fixing Roller and Slider

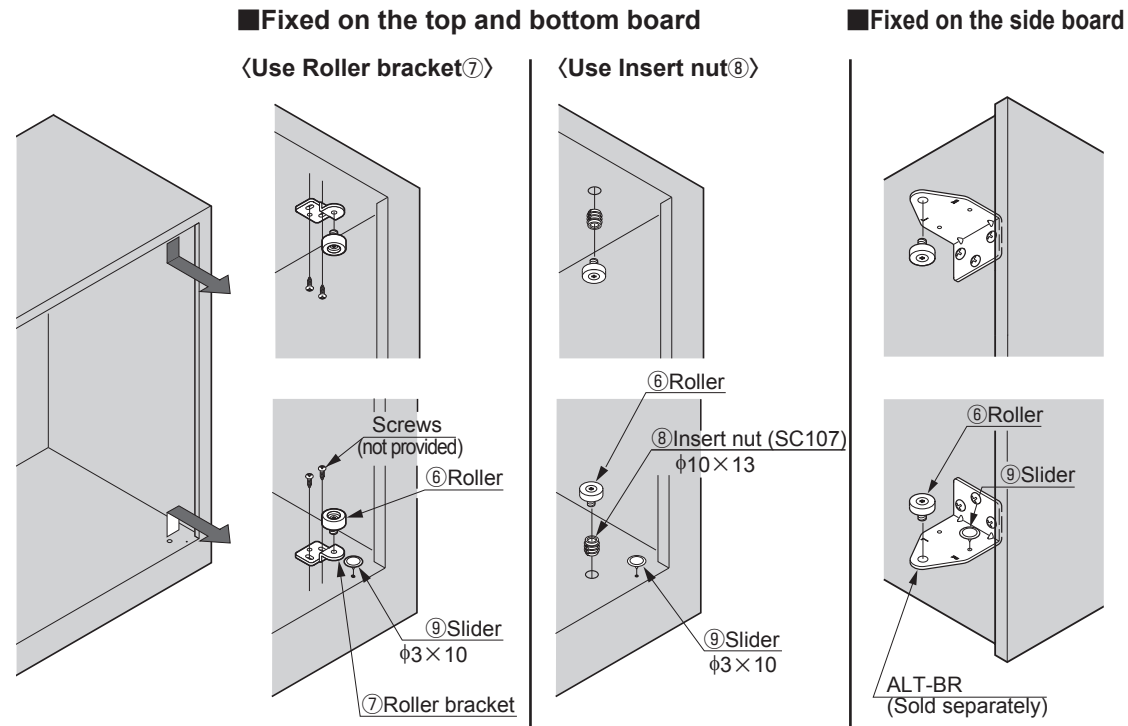

2 Mounting plate, Concealed hinge, Slider

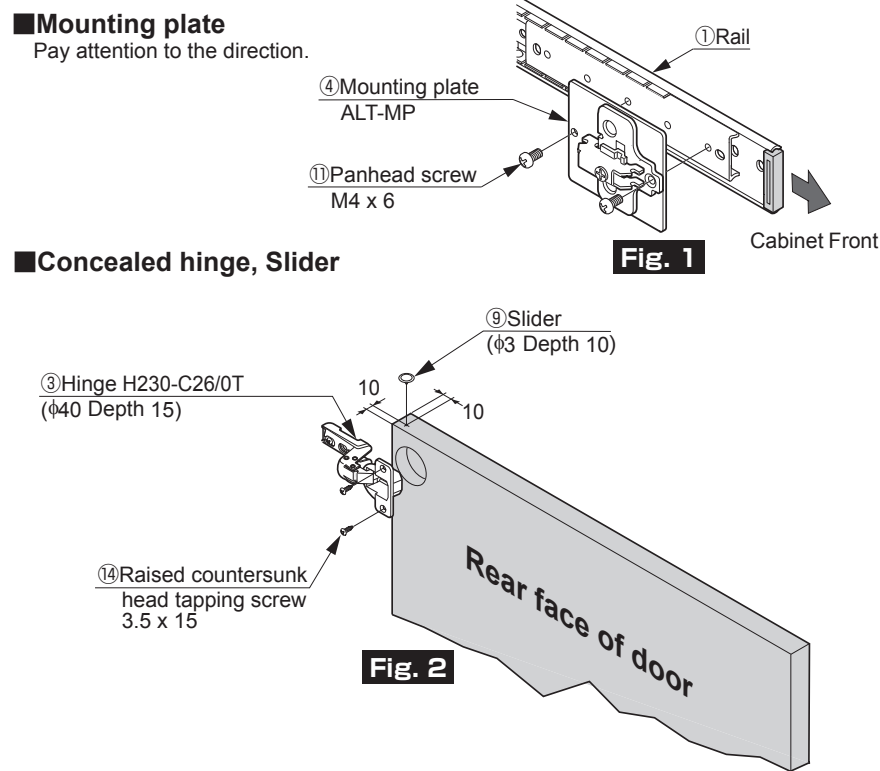

3 Mounting Rail temporarily, Fixing Door stopper

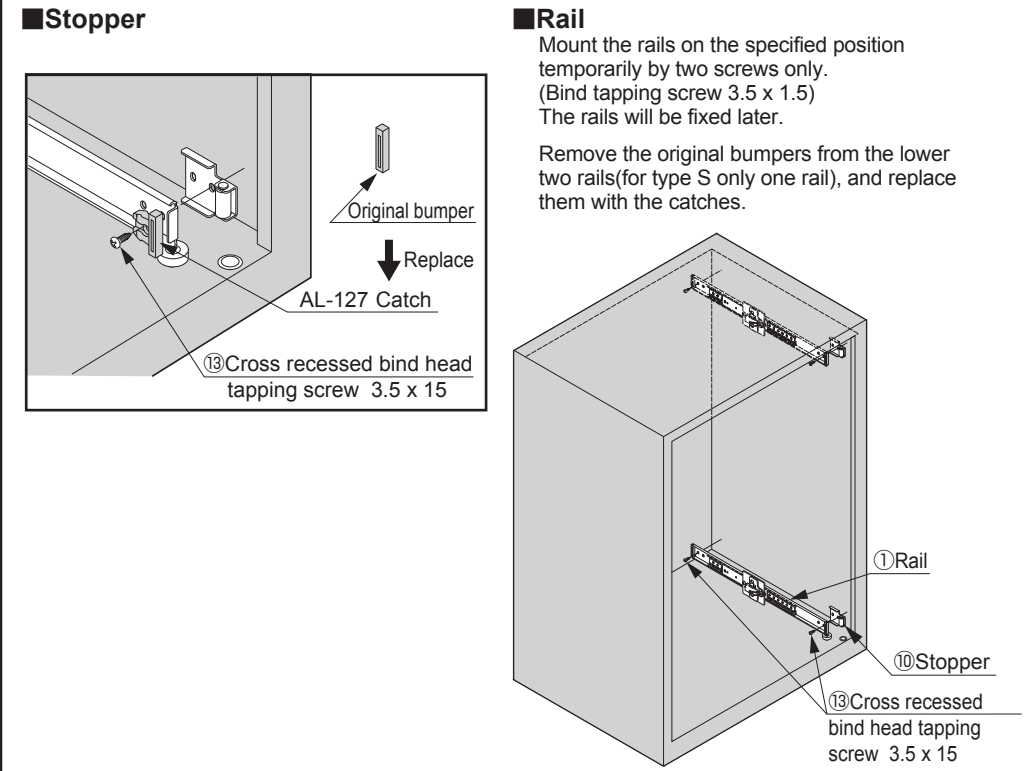

4 Fixing Connection plate

Mount the connecting plate on the Rails temporarily.

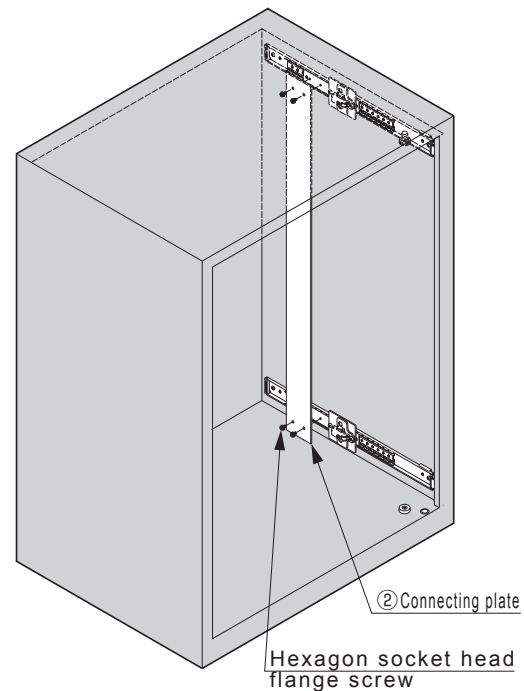

5 Alignment of Rails

- Hold the connecting plate and move it from the front end to rear end, and align the rails so that the connecting plate moves smoothly.
- Tighten the screws of the connecting plate, and check the movement again.
- Tighten the screws on the rails, and check the movement.
- If the movement is OK, fix the rails by fixing all of the screws.

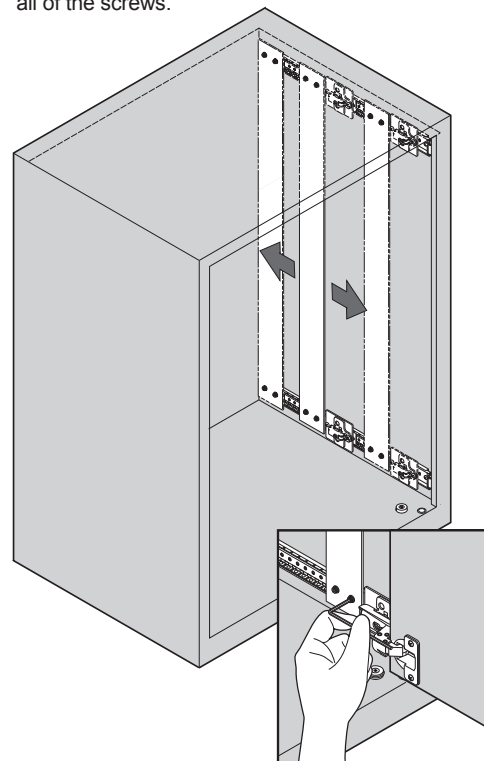

6 Hanging door

- Hold the door and mount concealed hinges on the mounting plates as shown.
- Ensure that all of the screws are tightened firmly.

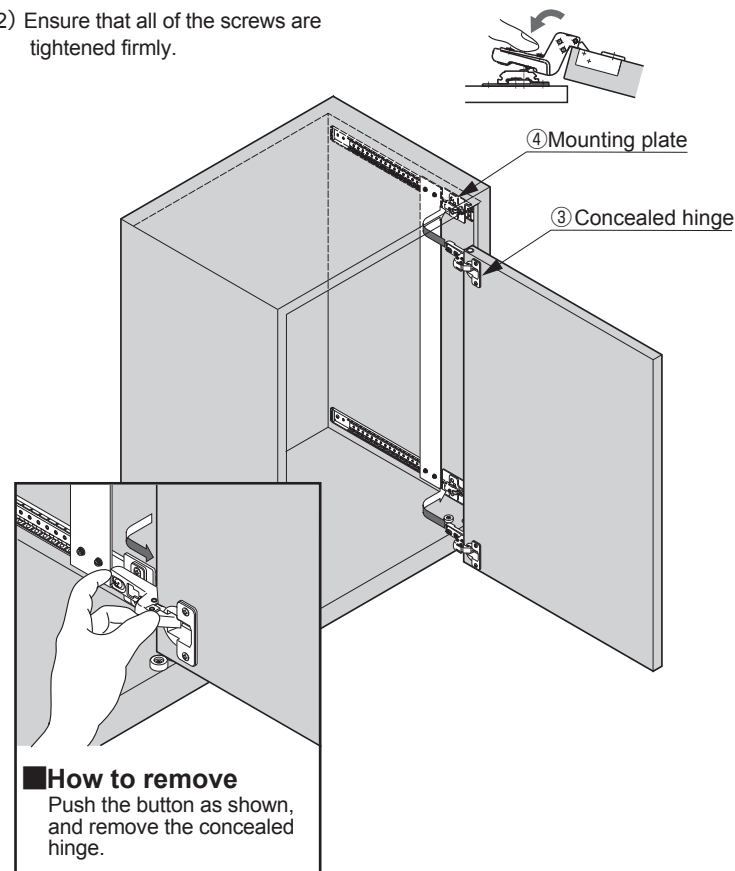

7 Adjusting door

How to adjust inclined door like the illustration below.

- Remove the door.
- Loosen hexagon socket head screw (12)
- While pushing the top of connecting plate (2) to the rear, re-tighten the hexagon socket head screw (12).

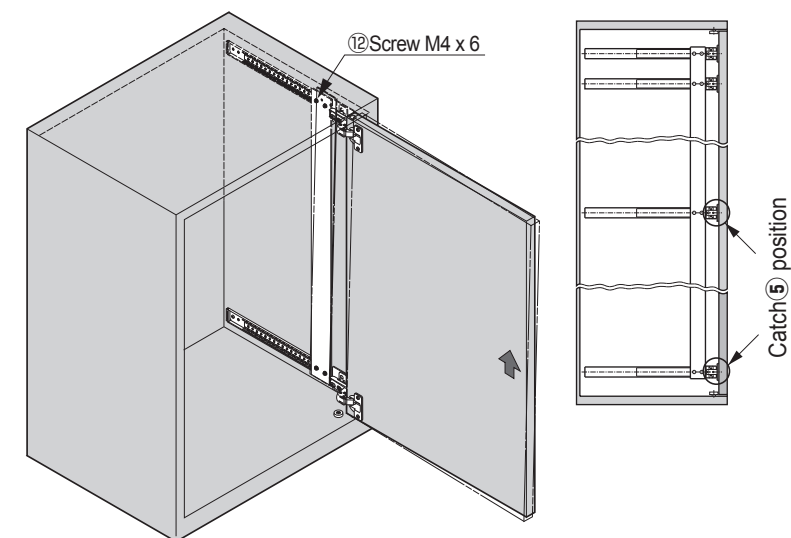

8 Adjusting door Position

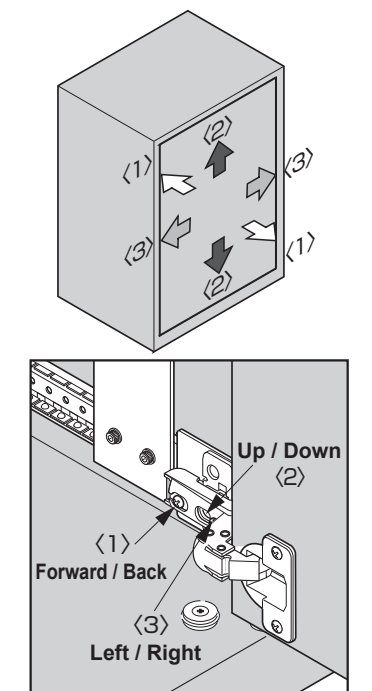

Caution

- Do not use motor screwdrivers.
- Be careful not to overtighten the screws.

SUGATSUNE KOGYO CO.,LTD
Tokyo, JAPAN
Phone: +81 (0)3 3866 2260 E-mail:export@sugatsune.co.jp

SUGATSUNE KOGYO (UK) LTD
Reading, UK
Phone: +44 118 9272 955 E-mail:sales@sugatsune.co.uk

SUGATSUNE EUROPE GmbH
Düsseldorf, GERMANY
Phone: +49 211 53812900 E-mail:sales@sugatsune.eu

SUGATSUNE SHANGHAI Co., LTD
Shanghai, CHINA
Phone: +86 21 3632 1858 E-mail:lamp@sugatsune.com.cn

Guangzhou, CHINA
Phone: +86 20 6639 3552 E-mail:lamp@sugatsune.com.cn

SUGATSUNE KOGYO INDIA PRIVATE LIMITED
Mumbai, INDIA
Phone: +91 22 28314490/91 E-mail:sales@sugatsune.in

SUGATSUNE AMERICA, INC
California, USA
Phone: +1 310 329 6373 E-mail:sales@sugatsune.com

Chicago, USA
Phone: +1 312 461 1081 E-mail:chicagoshowroom@sugatsune.com

SUGATSUNE CANADA, INC.
Phone: +1 514 312 5267 E-mail:support@sugatsune.ca

ISO9001(Japan Offices and Sugatsune America) and ISO14001(Chiba Production division and Logistics center), certified.

2019.02 0799-7