

LAMP® HG-JHM16 DAMPER HINGE INSTALLATION INSTRUCTIONS (For wood use.)

Thank you for selecting our product. Before starting installation, please read this manual thoroughly to ensure correct installation. Please keep this manual at hand for future reference.

Meaning of symbols





⚠ ABOUT THE PRODUCT

- 🔊 Range of use :Lids of a size and weight less than the damper torque See the Specifications table.
- 🔊 Be sure to install the left and right brackets correctly.

⚠ PRECAUTIONS

- 🚫 Do not use excessive force to the damper as this may result in damage.
- 🚫 This product is for indoor use only. Do not use outside or any where it will be exposed to water.
- ⚠ If the lid is released at a low angle, the damper may not work properly.
- 🔊 If the operating temperature increases, the door movement becomes quicker. If the temperature decreases, movement becomes slower. This is not a mechanical problem.

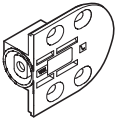
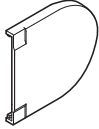
COMPONENT PARTS

No.	Part Name	Qty.	
①	Mounting Plate	L/R 1 each	
②	Damper Bracket	L/R 1 each	
③	Cover	2	
④	Screw (4×20)	12	

Installation Diagram (Lid, closed position)

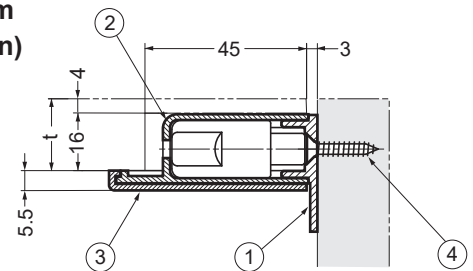

(Lid, 90° open position)

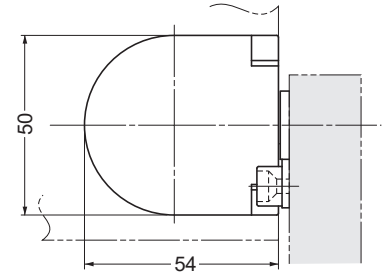

Item	Cover color	Damper Torque N·m (kgf·cm)	Damper color (bottom)
HG-JHM16-34BL	black	2 - 3.4 (20.4 - 34.7)	green
HG-JHM16-34WT	white		
HG-JHM16-50BL	black	3.4 - 5 (34.7 - 51.0)	black
HG-JHM16-50WT	white		

Maximum Torque Moment Calculations

$$T = m \times 9.8 \times L$$

T : Maximum lid torque (N·m)

m : Lid weight (kg)

L : Distance from rotation centre to lid centre of gravity (m)

$$L = D/2 - A$$

D : Lid length (m)

A : Length of lid back from rotation centre (m)

(Dimension A = 30-36 mm)

(Calculation example)

When D = 0.43 m, A = 0.032 m, m = 2.78 kg

$$T = 2.78 \times 9.8 \times (0.43/2 - 0.032) \div 4.99 \text{ N}\cdot\text{m}$$

Lid Preparation

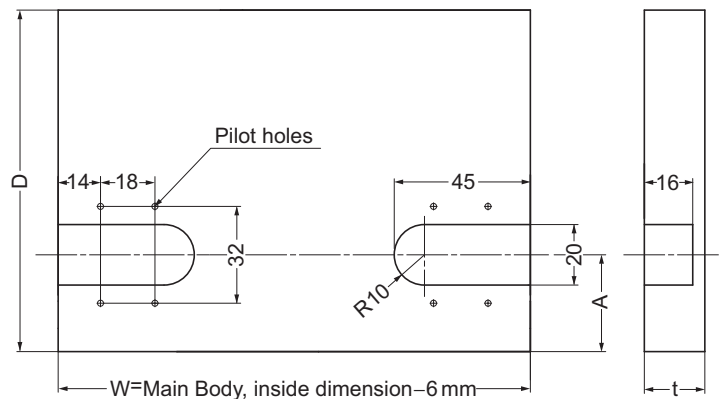

Standard Installation Specifications

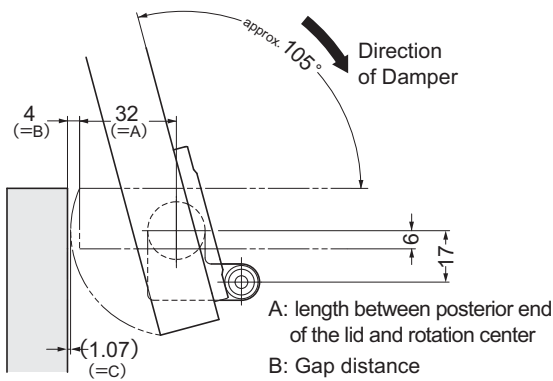

- Above example shows the lid of 20 mm thickness.
- Make sure that the gap C when the lid is open is 1 mm or more.

Installation Specifications for Rounded Lid Edge

Round the back edge of the lid to reduce the gap (B).

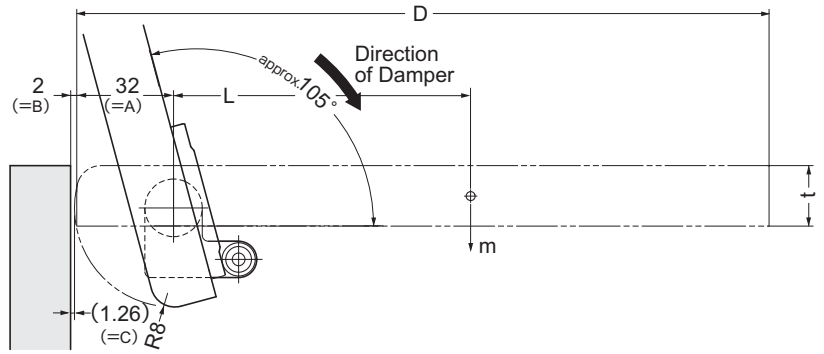

Installation

1. Mounting Plate Installation

- (1) Please drill 10 mm hole of 2.5 mm diameter as shown.
- (2) Fix location of mounting plate ① with provided screws. ④

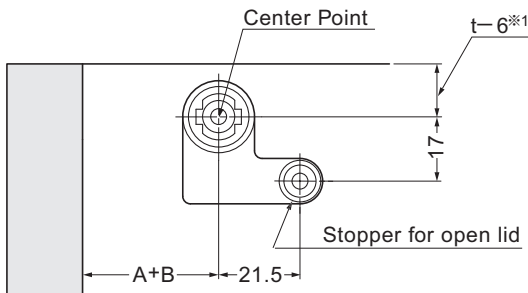

※1 : Dimensions when the upper part of lid and side panel are flash.

2. Bracket Assembly

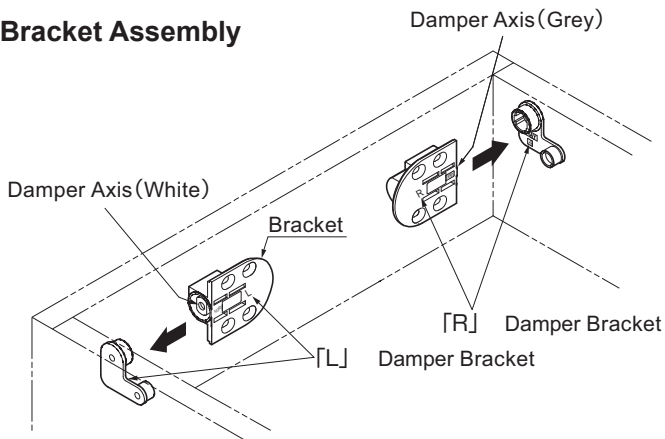

Damper Bracket [L] : Damper Axis Color – White
Damper Bracket [R] : Damper Axis Color – Grey

3. Lid and Bracket Cover Installation

(Refer to diagram below.)

- (1) Insert the lid vertically and mount onto brackets. ②
- (2) Fix with provided screws. ④
Close and open lid to check working damper.
- (3) Slide covers onto brackets.

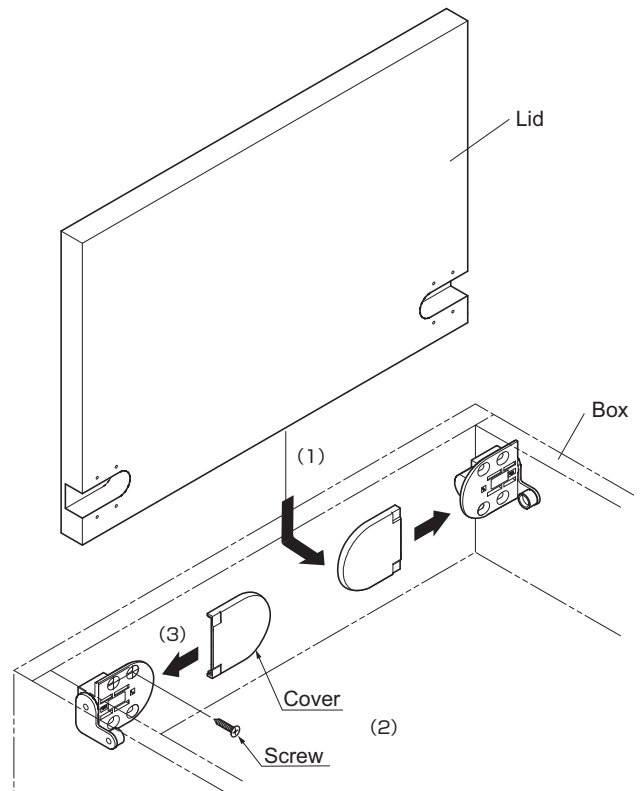

SUGATSUNE KOGYO CO., LTD.
Tokyo, JAPAN
Phone: +81 3 3866 2260
E-mail: export@sugatsune.co.jp

SUGATSUNE KOGYO (UK) LIMITED
Reading, UK
Phone: +44 1189 272 955
E-mail: sales@sugatsune.co.uk

SUGATSUNE EUROPE GmbH
Düsseldorf, GERMANY
Phone: +49 211 53812 900
E-mail: sales@sugatsune.eu

SUGATSUNE AMERICA, INC.
California, USA
Phone: +1 310 329 6373
E-mail: sales@sugatsune.com

Chicago, USA
Phone: +1 630 317 7072
E-mail: sales@sugatsune.com

SUGATSUNE CANADA, INC.
Montreal, CANADA
Phone: +1 514 312 5267
E-mail: support@sugatsune.ca

SUGATSUNE SHANGHAI CO., LTD.
Shanghai, CHINA
Phone: +86 21 3632 1858
E-mail: lamp@sugatsune.com.cn

Guangzhou, CHINA
Phone: +86 20 6639 3554
E-mail: lamp@sugatsune.com.cn

SUGATSUNE KOREA CO., LTD.
Incheon, KOREA
Phone: +82 32 220 0603
E-mail: sales@sugatsune-korea.co.kr

SUGATSUNE KOGYO INDIA
PRIVATE LIMITED
Mumbai, INDIA
Phone: +91 9867299597
E-mail: sales@sugatsune.in
Delhi, INDIA
Phone: +91 9867299597
+91 11 45093636
E-mail: sales@sugatsune.in