

# LAMP® STACKABLE PARTITION DOOR SYSTEM FDPN40P1D

## Installation Manual (Parallel Stacking)

Thank you for selecting our product. Before starting installation, please read this manual thoroughly to ensure correct installation. Please keep this manual at hand for future reference.

### ABOUT THE PRODUCT

- This product is parts set for installation of sliding partition for indoor use.  
It is possible to stack panels at a side in parallel.
- Since panels are suspended, no bottom track is needed.  
Thanks to exclusively designed rollers, smooth movement of panels are realized.

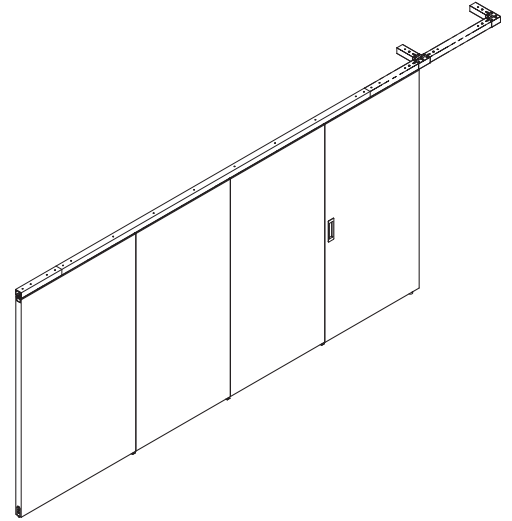

### APPLICABLE PANELS

Partition face	Number of panels	Panel width		Panel height	Panel thickness	Panel weight (each panel)	Panel vertical adjust range
		Stackable door, Stackable panel	Sliding panel				
One	3 to 6 (※ <sup>1</sup> )	500 - 1000 mm (※ <sup>1</sup> )	500 - 1300 mm (※ <sup>1</sup> )	Max. 2500 mm	34 - 40 mm	Max. 40 kg	Upward: 0mm Downward: 7mm

※<sup>1</sup> These sizes are available by the choice of stacking track.

### FOR YOUR SAFE WORK AND CORRECT INSTALLATION

#### Meaning of symbols

 <b>Warning Caution</b>	 <b>Prohibited</b>	 <b>Required</b>
---	---	---







**! WARNING** If not followed, death or serious injury may result.

- ❗ This partition door system should be installed by a qualified person. If the system is not installed correctly, the panel will not operate smoothly, and may cause injury.
- ❗ It is necessary to manufacture the frame with sufficient strength so that it endures the weight of the panel and any impact upon opening / closing the panel. Only use designated screws and ensure that they are fastened firmly. A frame with poor strength or loose screws might result in the panel falling and causing injury.
- ⊘ Do not try to use this product for anything other than its original purpose. Do not use any part for applications outside of its specification.
- ⊘ Do not disassemble nor modify any parts other than those described in this document.

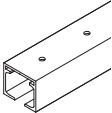

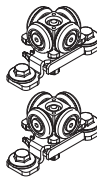
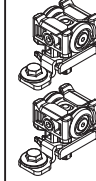

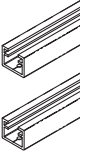
**! Caution** If not followed injury or damage may result.

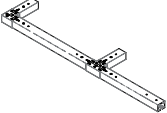
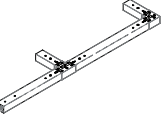

- ❗ This product is a part for architectural fittings. After installation, make sure to test the finished product thoroughly to ensure that it is well-functioning and safe.
- ❗ Make sure to follow the designated dimensions, specifications, and horizontal/vertical angles. Make sure that the frame is not warped, since it may affect the movement of the panel.
- ❗ If cutting any parts, make sure to remove any burrs before installation. Also check the upper rail for any left-over burrs or scraps and remove these.
- ❗ When using electric tool, pay attention to avoid over-tightening.
- ❗ Make sure to check the screws for slack at regular intervals (one month from first usage, half a year, and then one time every year is recommended).

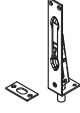
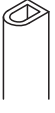
# COMPONENT PARTS

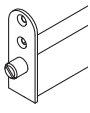
		①	②	③	④	⑤	⑥	⑦	⑧	⑨							
Left or right stacking	No. of panels	Upper track   There is also a recessed mount separately.	Stacking track  ※Refer to the table on page 4 for the choice of stacking track.	Connecting plate (one piece attached to ②) 	Recessed rollers for stackable door 	Recessed rollers for stackable panel 	Recessed rollers for sliding panel 	Sliding door stopper (Attached to ④) 	Hanging bracket (2 pcs/set) 	End cap 							
		3	1	 1set	1	1set	1set	1	3 sets	6							
4	2	2									2	4 sets	8				
5														2	2	3 sets	10
6																	
Right stacking	3	1	 1set	1	1set	1set	1	3 sets	6								
	4									2	2	3 sets	8				
	5	2		2				4 sets	10								
	6													6 sets	12		

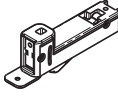
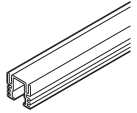
Stackable door is included in "No. of panels"  
Attachment: Adjust spanner (1 pc)

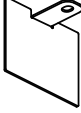
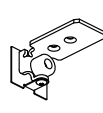
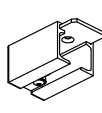
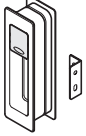
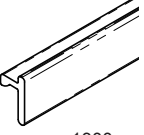
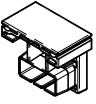
Optional Parts	⑩	⑪	⑫	⑬	⑭	⑮	⑯
No. of panels	Flush bolt 	Gasket 	Counter part for gasket 	Door bottom tightener 	Magnet floor guide pin 	Counter plate for magnet floor guide 	Magnet floor guide track 
3	2	1	1	2	3	2	1
4	3	2	2	3			
5	4	3	3	4			
6	5	4	4	5			
	Must be used on stackable panel to lock.	Must be used to hide the gap between panels. To be used by pairs.		To hide the gap between panel and floor.	For straight travel of stackable door		

⑰	⑱	⑲	⑳	㉑	㉒	㉓
End plate FDP40-TREP 	Stopper FDP40-ESTP 	Stopper FDP40P-ESTP 	Recessed pull HH-P135 	Gap cover  1300mm	Catch A  4 pcs./Set	Catch B 
—	—	—	—	Required number (Cut and use)	Required number (P.20)	2~4pcs/panel (width: >700) (P.20)
To cover the end of track (This is not a stopper.)	For upper track	For stacking track	For stackable door	For concealing gaps between upper rail and panel. <b>⚠ Caution</b> Please make sure not to bent the gap cover. If not, it will deform and cause floating and deflection.		

# POSITION OF PANELS

## Right stacking

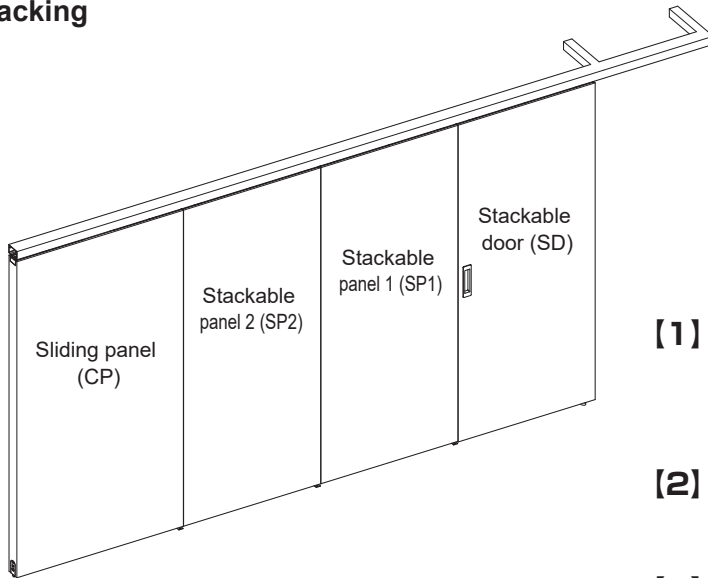

### [1] Stackable door (SD)

Use as a sliding door when the panels are closed.  
Use magnet floor guide to travel straightly.

### [2] Stackable panel 1 (SP1)

A panel located next to stackable door.

### [3] Stackable panel 2 (SP2)

A panel located between stackable panel 1 and sliding panel.

## Left stacking

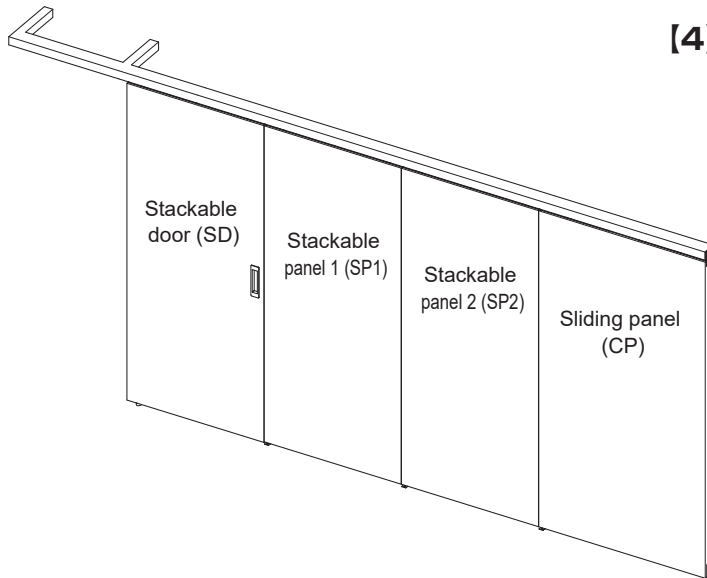

### [4] Sliding panel (CP)

A panel furthest from stacking track  
This panel travels only on the straight part of the track.

## Parts for each panel (Optional Parts)

### [1] Stackable door (SD)

### [2] Stackable panel 1 (SP1)

### [3] Stackable panel 2 (SP2)

### [4] Sliding panel (CP)

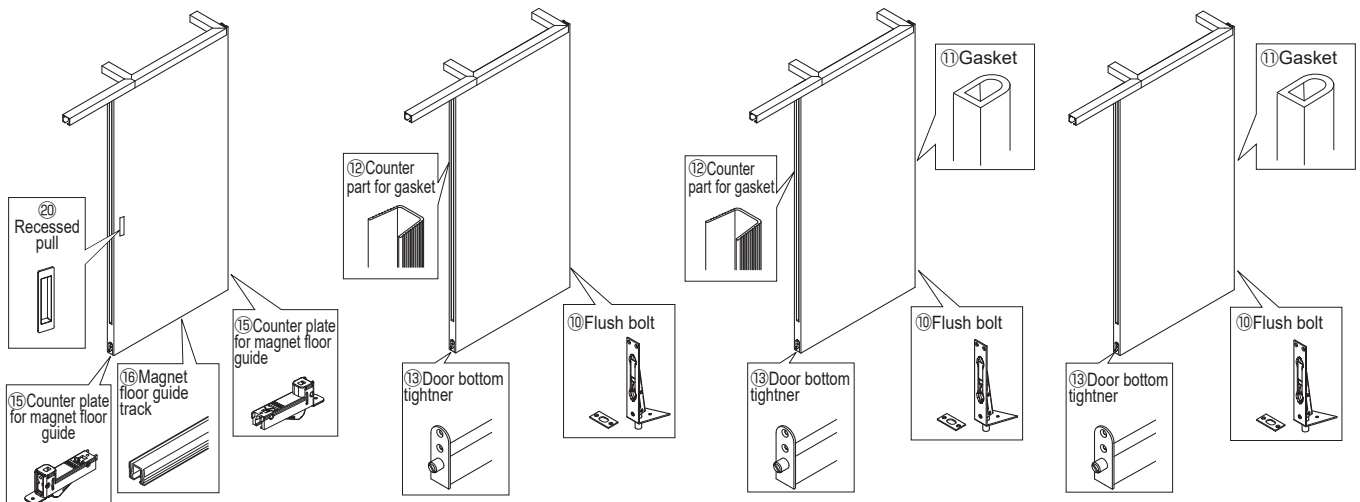

# INSTALLATION DRAWING (EXAMPLE)

This document uses the surface mount rails to provide installation instructions.

Stacking track	Left or right stacking	No. of panels	Dimension of stacking track				Panel width			Hanging bracket	
			P	D	Dsr	Lsr	Stackable door	Stackable panel	Sliding panel	Part No.	Lh
FDPN40P - TRMSL - P34D16	Left	3 - 4	340	160	183	623	500 - 700	500 - 700	500 - 700	FDP40-DTR240	240
FDPN40P - TRMSR - P34D16	Right										
FDPN40P - TRMSL - P54D16	Left	5 - 6	540	260	283	823	700 - 1000	700 - 1000	700 - 1300	FDP40-DTR340	340
FDPN40P - TRMSR - P54D16	Right										
FDPN40P - TRMSL - P54D26	Left										
FDPN40P - TRMSR - P54D26	Right										

The drawing shows the installation of right stacking.  
In case of left stacking, positions and direction of the parts are mirror image.

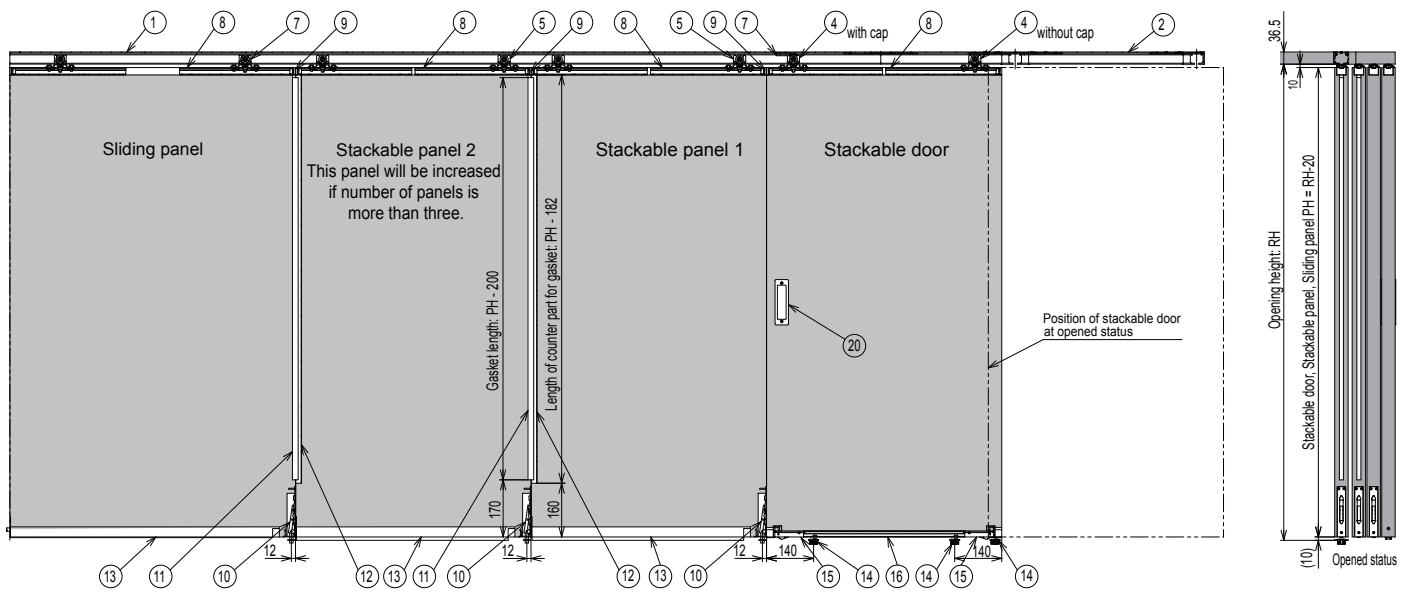
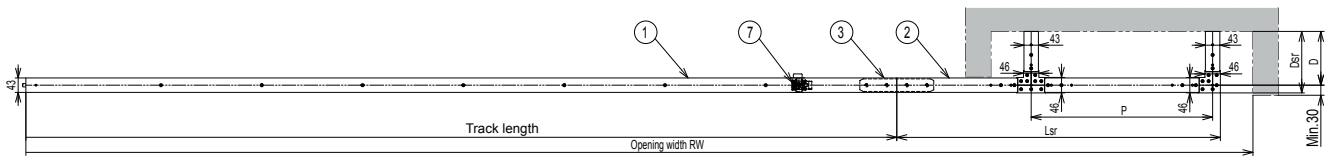
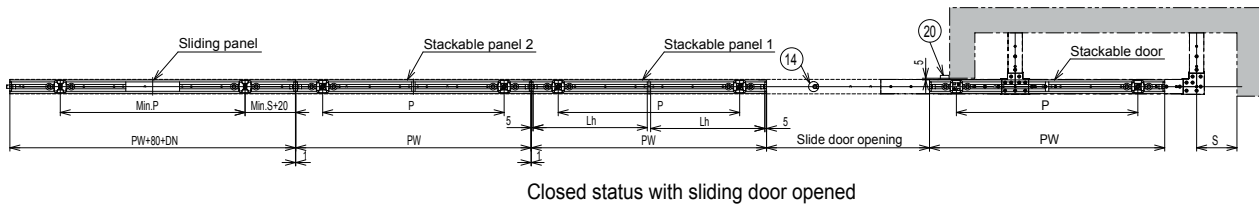
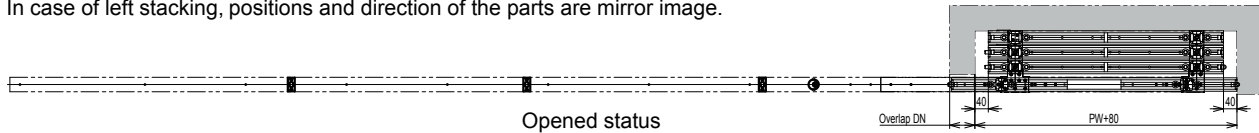

# PANEL PROCESS DIMENSIONS

## ■ Stackable door (SD)

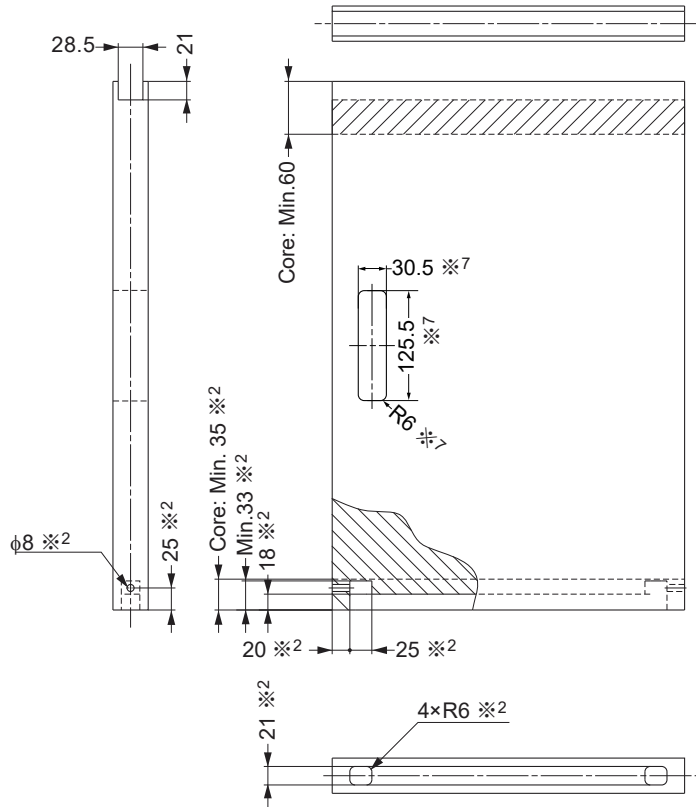

## ■ Stackable panel 1 (SP1)

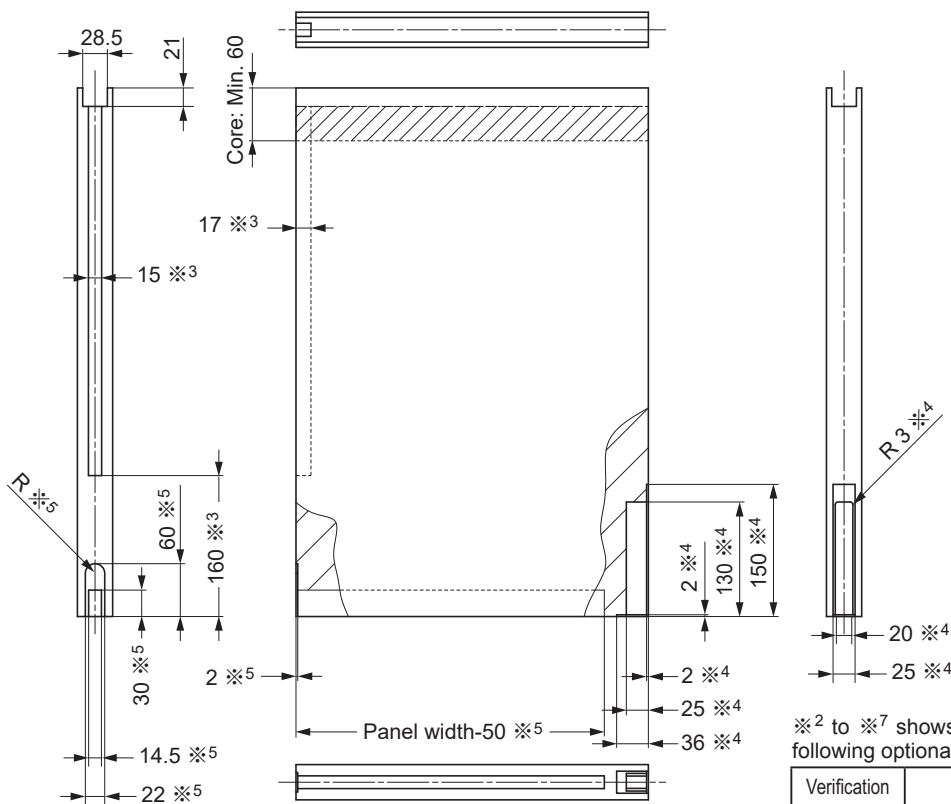

※<sup>2</sup> to ※<sup>7</sup> shows process dimensions only when following optional parts are used.

Verification	Part name
※ <sup>2</sup>	15 Counter plate for magnet floor guide 16 Magnet floor guide track
※ <sup>3</sup>	12 Counter part for gasket
※ <sup>4</sup>	10 Flush bolt
※ <sup>5</sup>	13 Door bottom tightner
※ <sup>7</sup>	20 Recessed pull

■ Stackable panel 2 (SP2) This panel will be increased if number of panels is more than three.

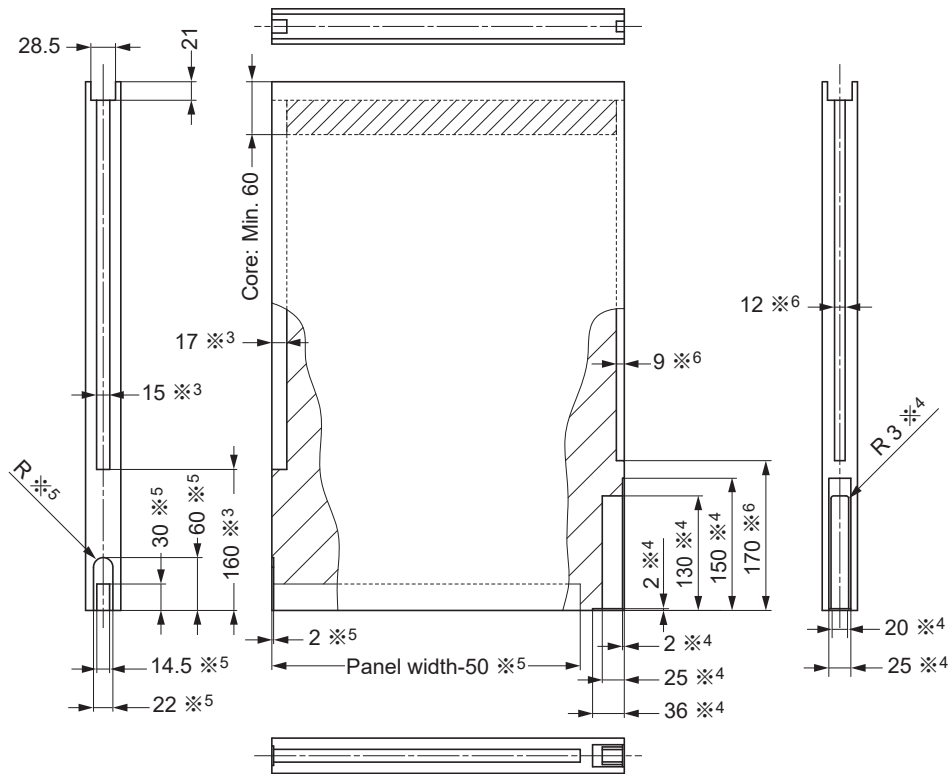

■ Sliding panel (CP)

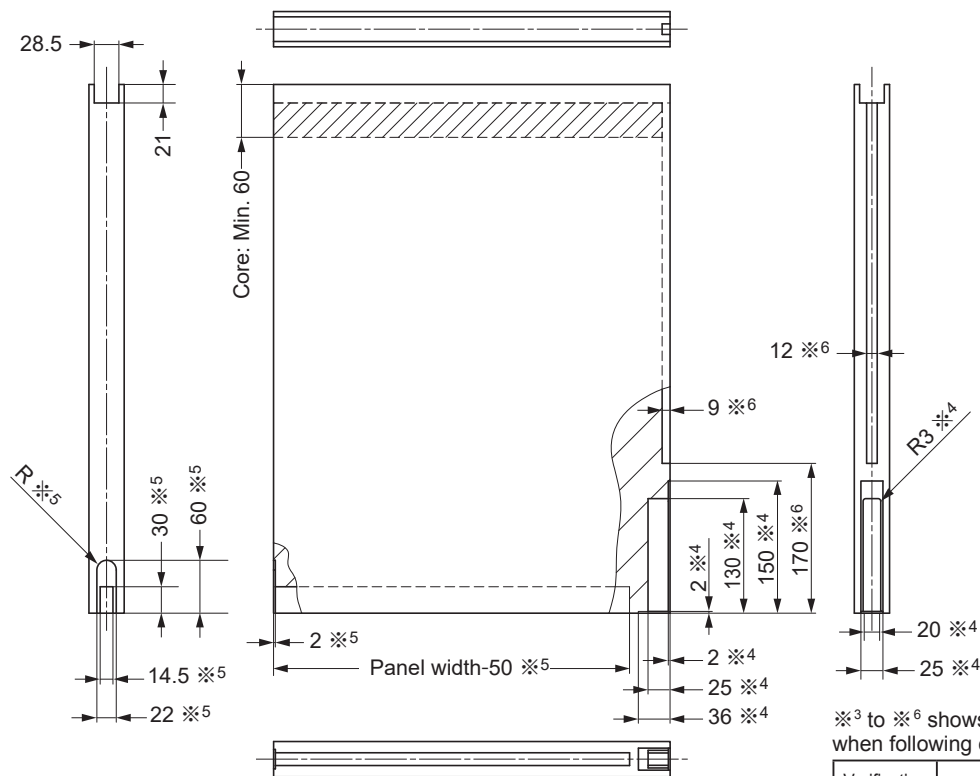

※<sup>3</sup> to ※<sup>6</sup> shows process dimensions only when following optional parts are used.

Verification	Part name
※ <sup>3</sup>	⑫ Counter part for gasket
※ <sup>4</sup>	⑩ Flush bolt
※ <sup>5</sup>	⑬ Door bottom tightner
※ <sup>6</sup>	⑪ Gasket

# CHECK POINTS FOR INSTALLATION

## [1] Structure of beam

Arrange a beam for track with reinforcing material to prevent track from warping.

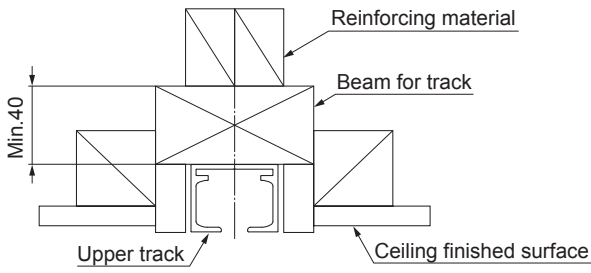

Make sure that the ceiling is strong enough to support a load of 240kg

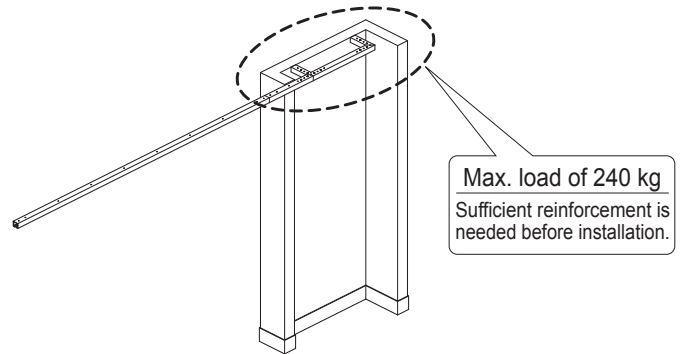

## [2] Check the ceiling for sag and floor for warp.

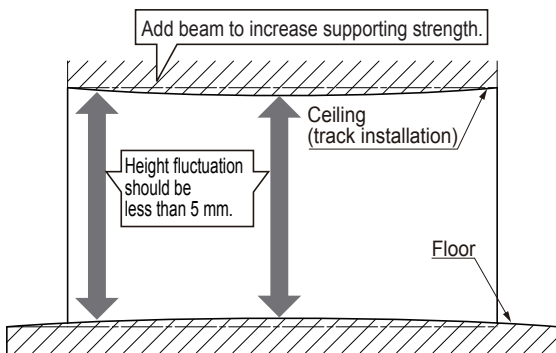

## [3] Process when recessing the track

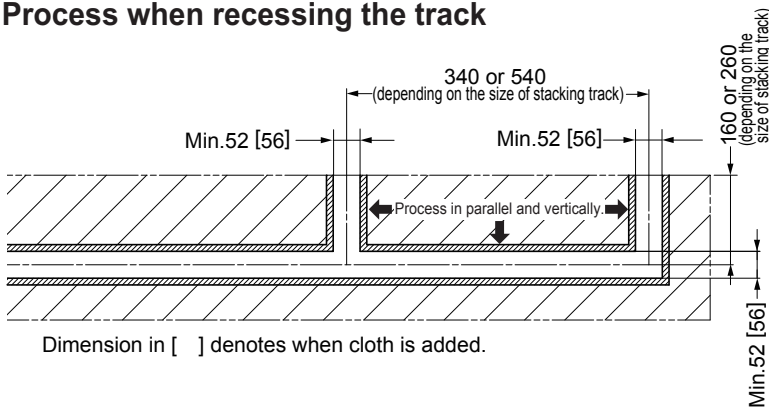

**Caution**

! The groove should be processed so that the track would not be deformed.

- Width of groove
- Right angle
- Parallel

## Cross section

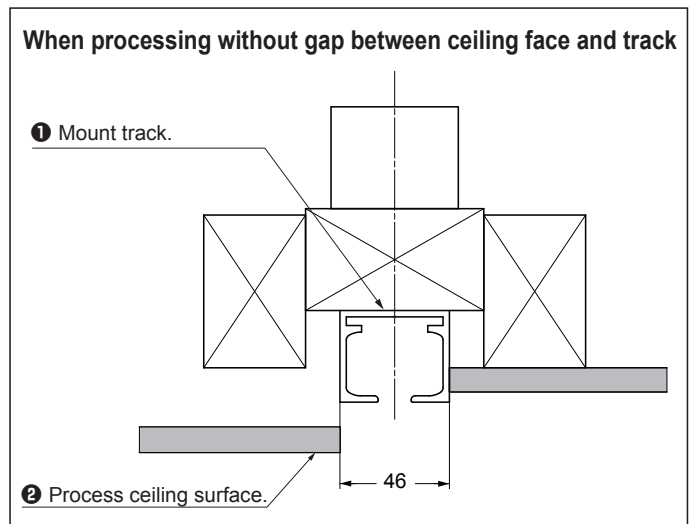
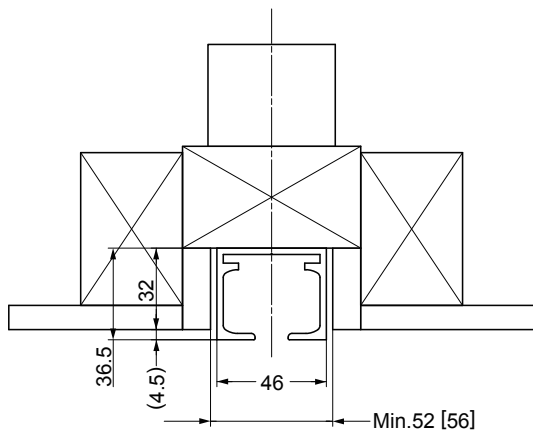

# TOOLS NEEDED FOR INSTALLATION



Phillips Screwdriver #2



Screwdriver ※11



Adjust spanner  
Order code: 250-017-168  
Part No.: FD30-FSP



Spanner 10 mm

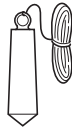

Plumb ※8, ※9



Adhesive for synthetic rubber and wood ※10



Drill bit: φ12 ※9, φ24 ※8

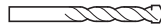

Drill bit: φ3.5 ※8

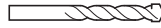

Drill bit: φ5 ※11  
φ4, φ6 ※12



Pan head tapping screw ※8, ※11



Saw for metal ※11

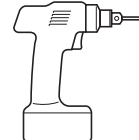

Drill ※8, ※9  
※11, ※12

## Tool for magnet guide pin

(Choose either one)



Spanner 22 mm  
Order code: 250-022-252  
Part No.: FD80-HHSP

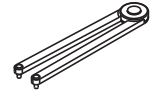

Special tool  
Order code: 270-180-388  
Part No.: Z059

※8: For installation of magnet floor guide

As for drill bit φ24, choose suitable one according to the material of the floor.

※9: For installation of flash bolt. As for drill bit φ12, choose suitable one according to the material of the floor.

※10: For installation of gasket (acrylic modification silicon resin, elastic adhesive or the like)

※11: For installation of door bottom tightner.

※12: For hole processing of tracks. (As for φ4, see 11 - [2].)

# INSTALLATION PROCEDURES

This describes the installation of right stacking. In case of left stacking, positions and direction of the parts are mirror image.

## 1 Cutting, Hole Processing for Long Parts

### [1] Upper track

(Refer to the shop drawing about the cutting length.)

#### ⚠ Caution

❗ Remove any dirt or aluminum chips from the track.

Track when one upper track is installed.

End track when two upper tracks are installed.

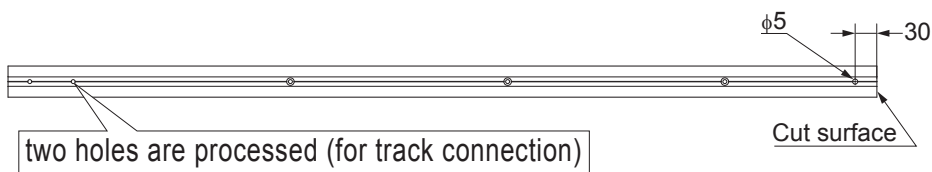

Intermediate track when two upper tracks are installed.

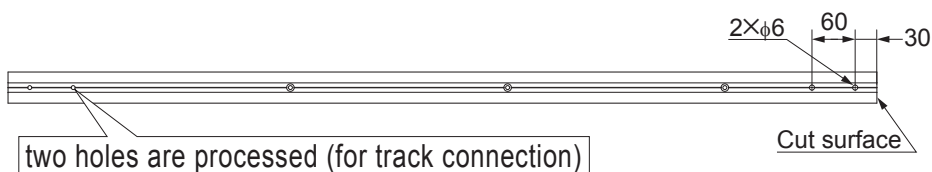



## [2] Magnet floor guide track

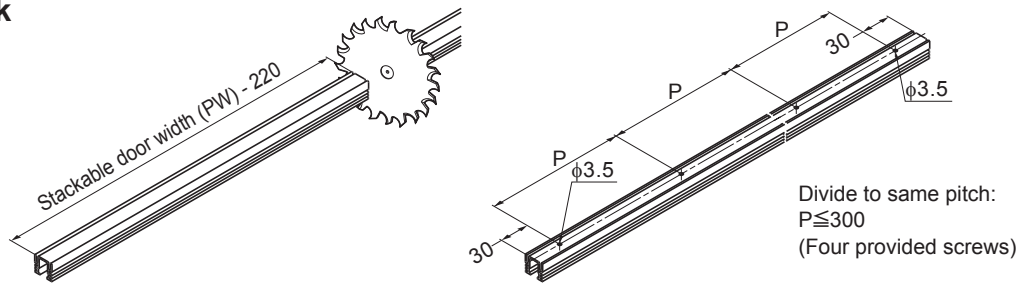

## [3] Gasket, Counter part for gasket

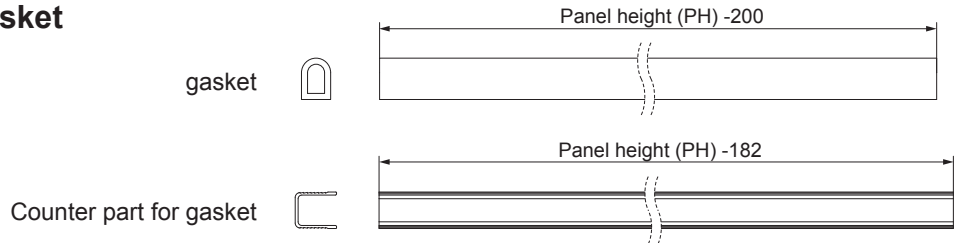

## [4] Door bottom tightener

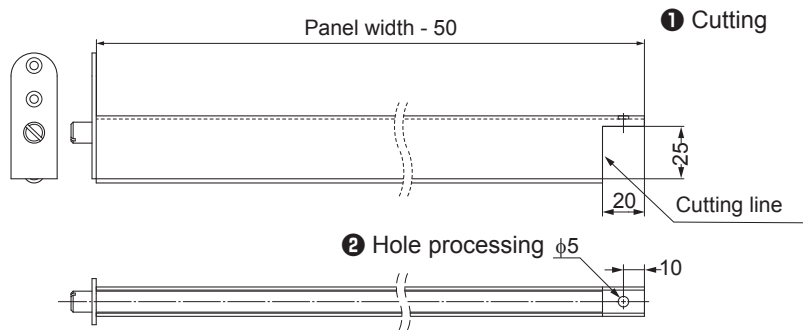

## [5] Hanging bracket (When using together with the optional gap cover)

<For panel width : 500 - 519,  
700 - 719>

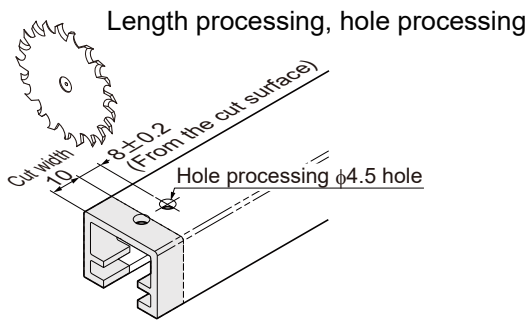

<Panel and door width  $\geq 700$ >

Hole processing for Catch B installation  
(1 hole per piece)

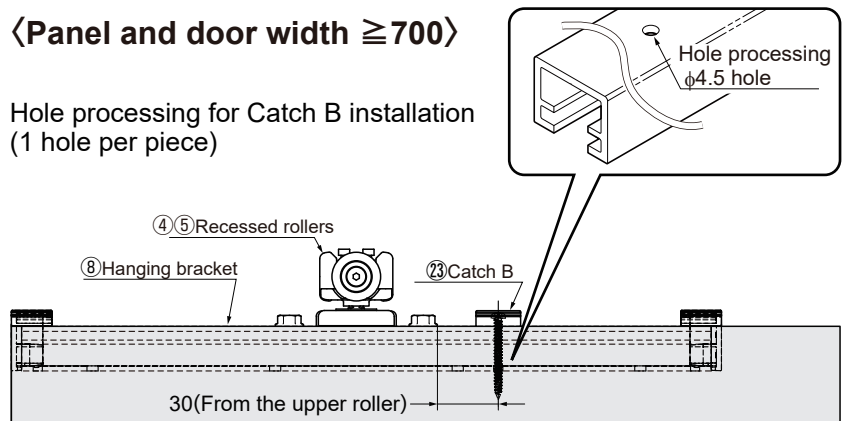

## [2] Parts Assembly on Panels

### [1] Hanging bracket

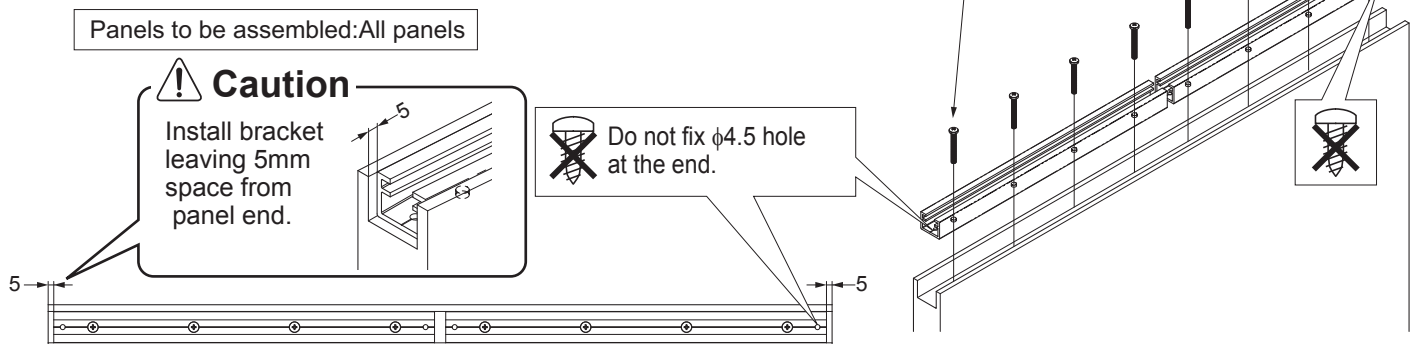



### [5] Door bottom tightner

Panels to be assembled  
 • Stackable panels (SP)  
 • Sliding panel (CP)

Provided screws

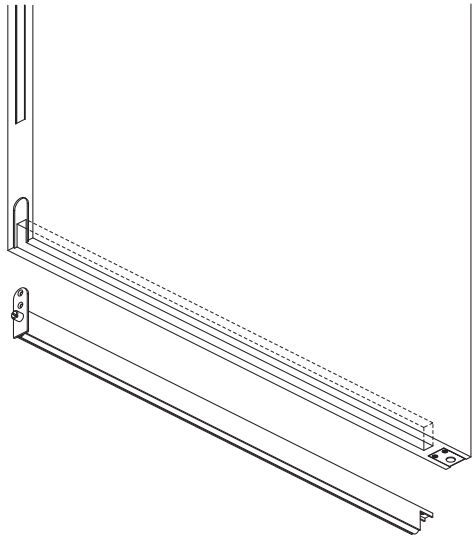

Below parts in the package are not necessary.

Pan head tapping screw 4x20  
 (Not provided)

### [3] Mounting Stacking Track

Refer to the shop drawing about the position of the track.

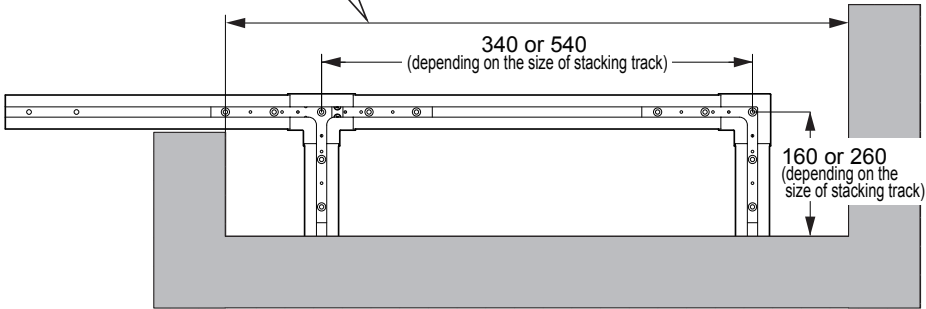

Do not fix these two holes in this stage. It will be fixed later.

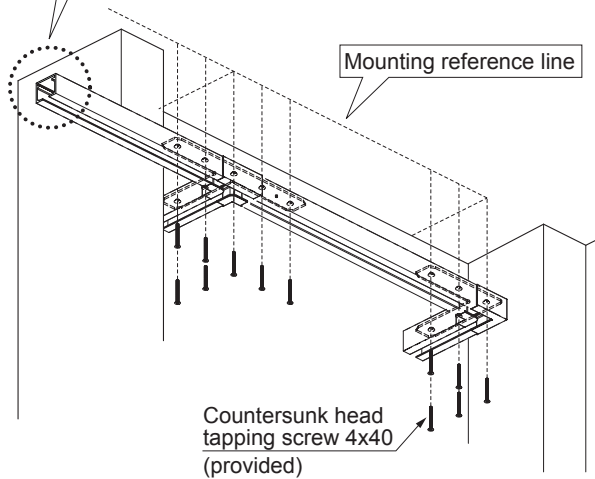

## 4 Assembling Recessed Rollers, Hanging Panels

### (1) Workflow

- 1 When installing ②① gap cover (option): install catches A and B in the center.  
※ Refer to P.20 for placement and quantity.

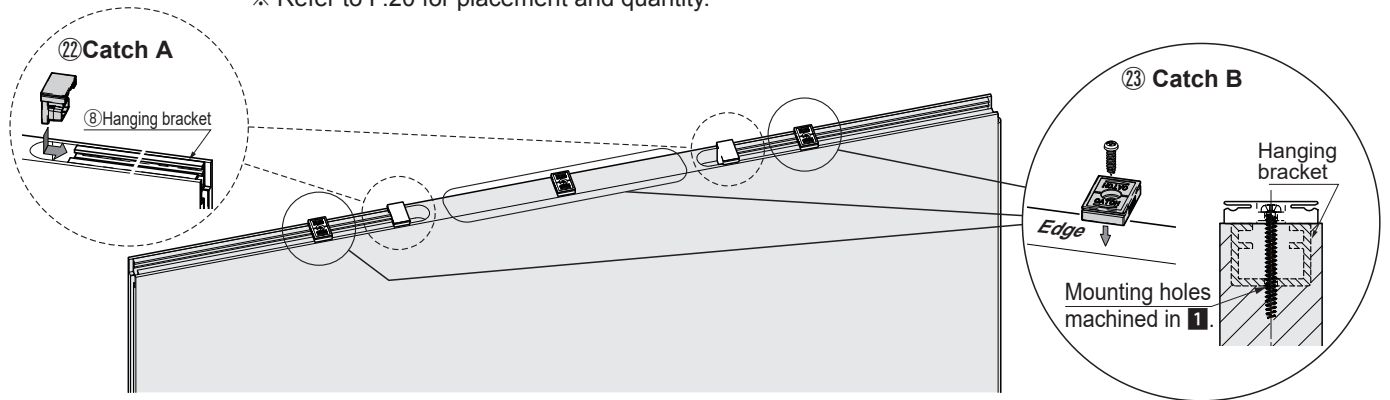

- 2 Loosen tightening bolts on recessed rollers.
- 3 Insert recessed rollers to stacking track.

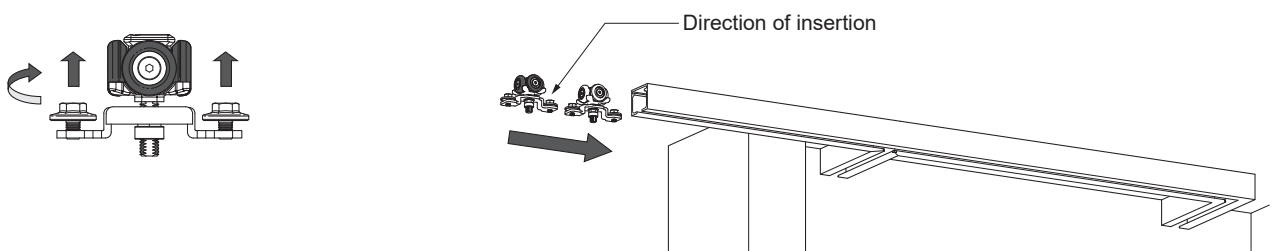

- 4 Insert the top rollers from both sides.

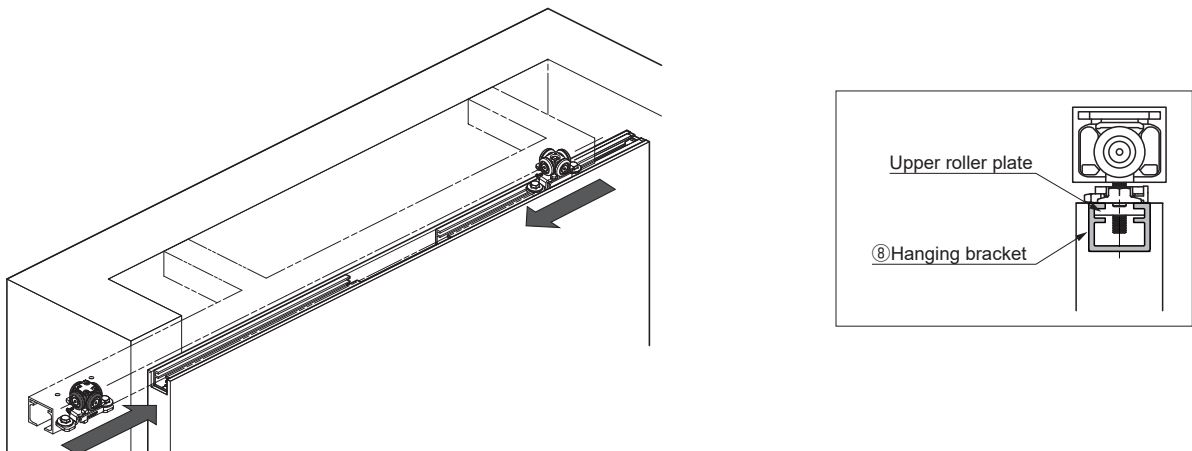

- 5 Adjust positions of recessed rollers, then tighten the bolts.

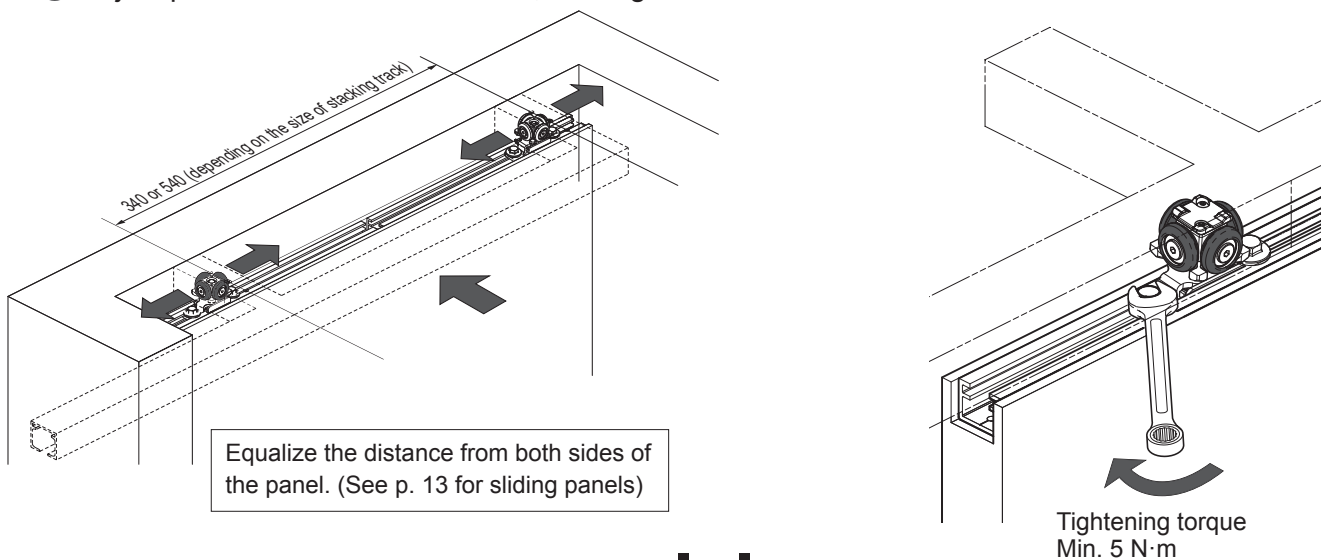

**[2] About the Recessed Rollers on each Panel**

Note that recessed roller to be assembled is different depending on panel.  
Install correct roller according to the explanation below.

**(1) Stackable door (SD) - Red plastic bag**

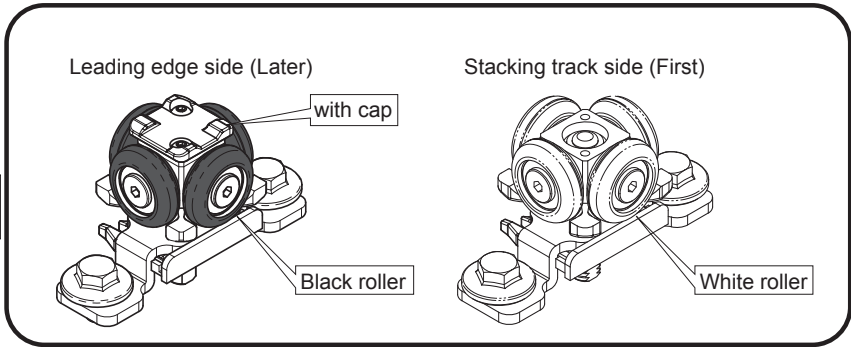
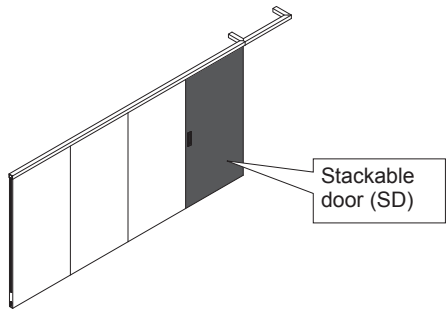

**(2) Stackable panel (SP1, SP2) - Black plastic bag**

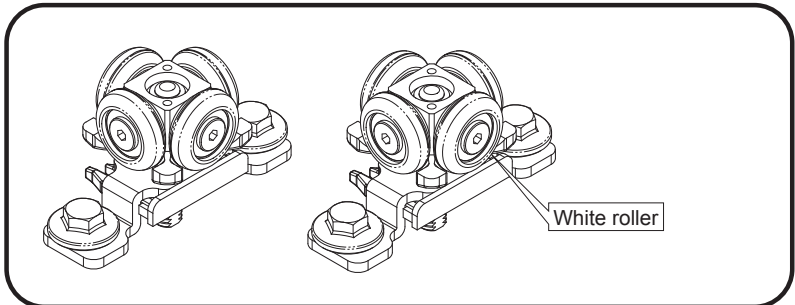
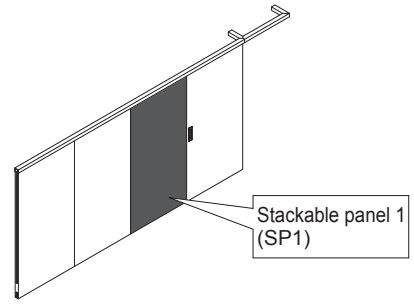

**(3) Sliding panel (CP) - Blue plastic bag**

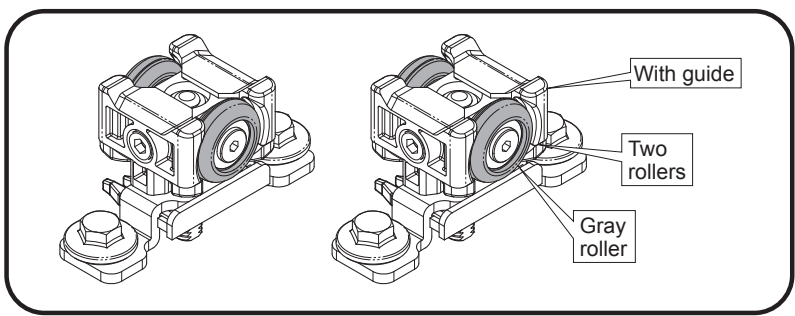
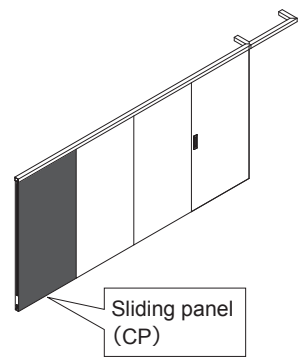

**■ Positioning of recessed rollers**

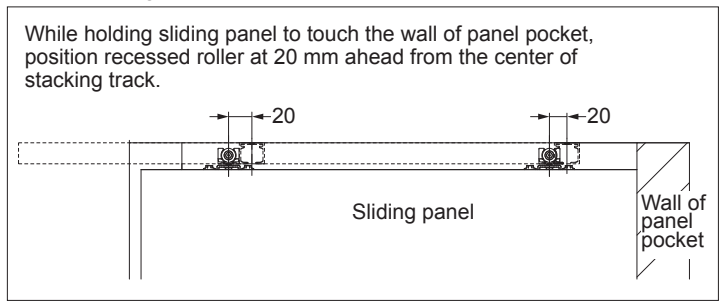

## 5 Check Movement of Panels

### [1] Stackable door, Stackable panel

- Repeat sliding out operation of each panel from stacked position for several times to confirm the position of rollers.
- If improper movement is found, readjust the position of rollers.

### [2] Sliding panels

- Confirm that the rollers never reach the parallel part of staking track.  
(Note that sliding panel is designed to move linear only.)

## 6 Mounting Upper Track

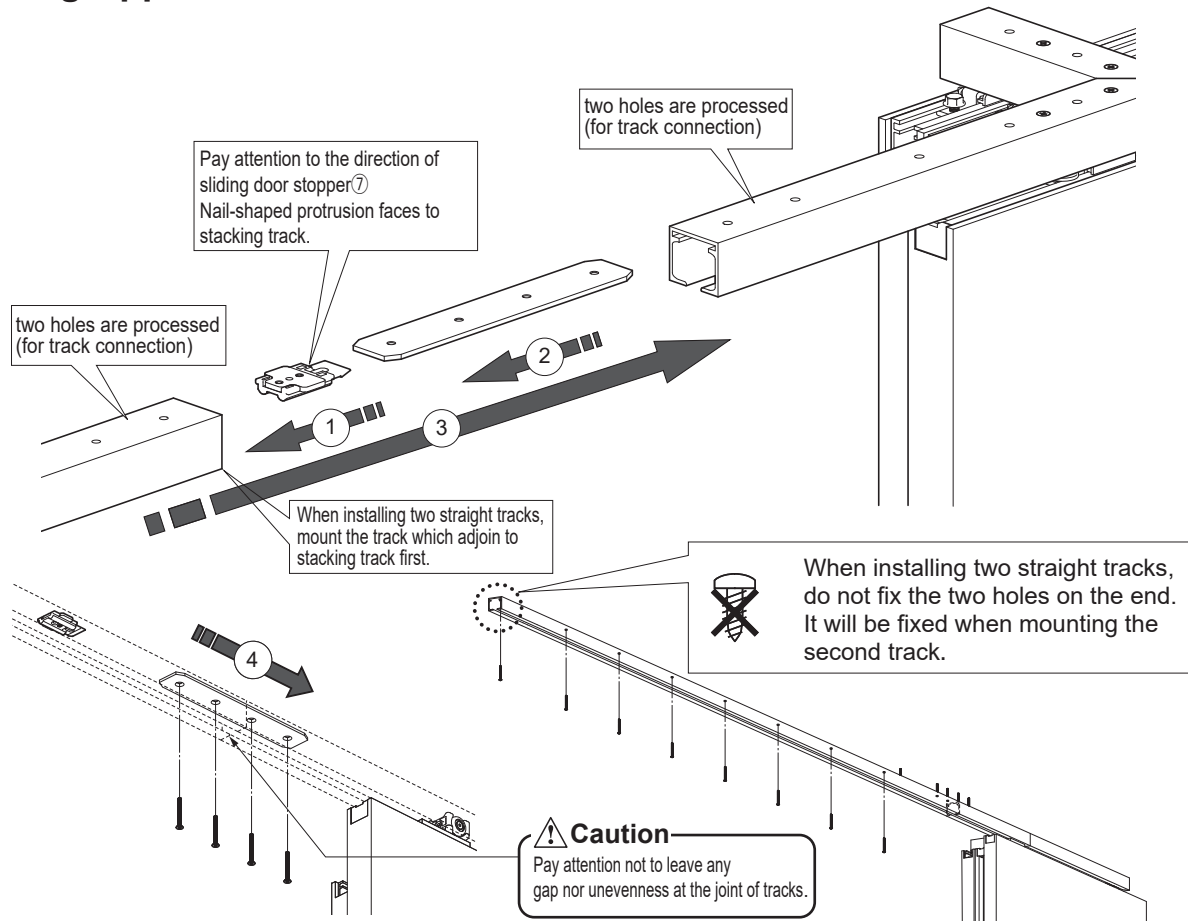

### How to joint two upper tracks

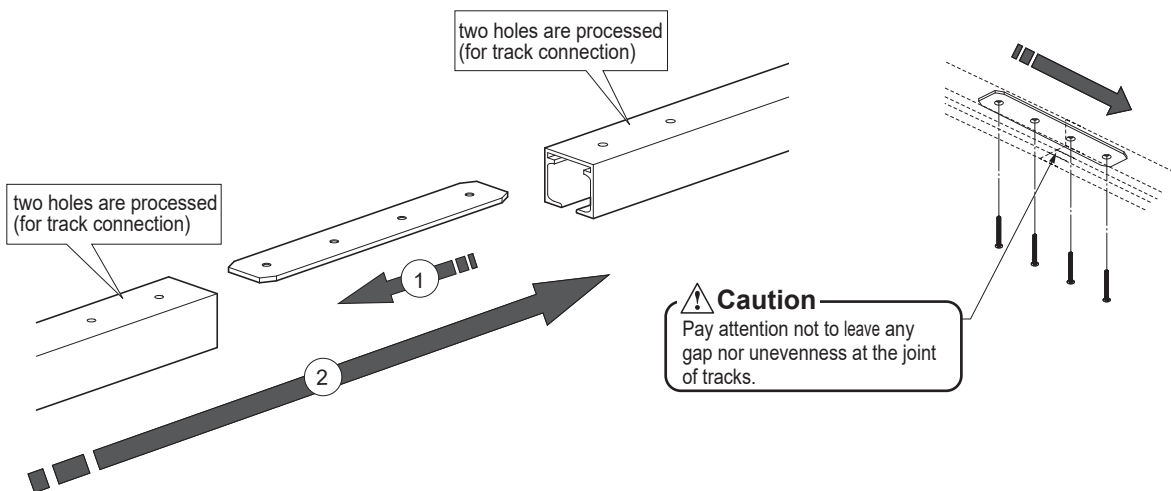

## 7 Panel-to-Panel Alignment (Adjusting Vertical Position)

**[1]** Pull out all stacked panels and doors along straight part of the track as shown.

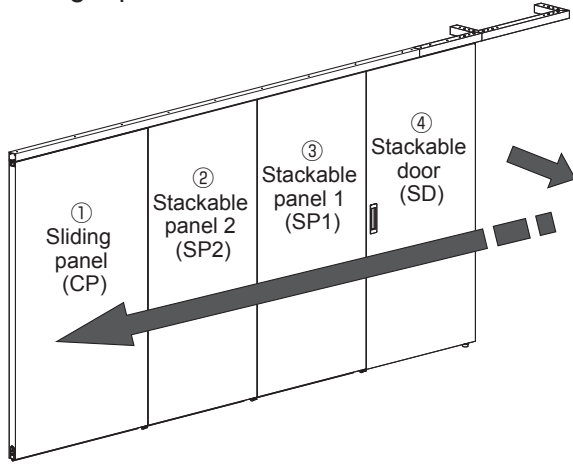

**[2]** Pull out nut holder.

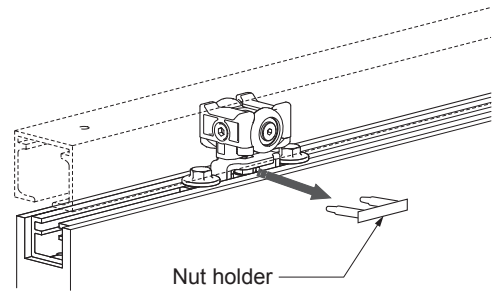

**[3]** Adjust vertical position.

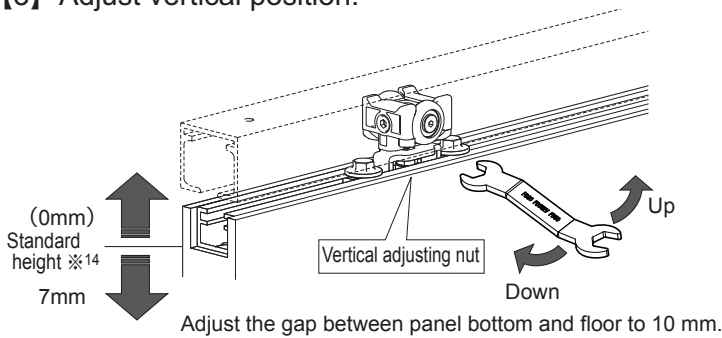

※14 Default setting;  
Gap between track and panel: 10mm

**[4]** Re-insert nut holder

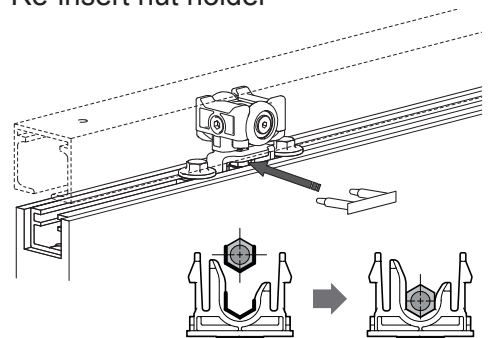

### ⚠ Caution

Align the nut to the nut holder before inserting so as not to damage the nut holder.

## 8 Mounting Strike for Flash Bolt

Mount each strike in the order of ① to ③, while positioning one by one.

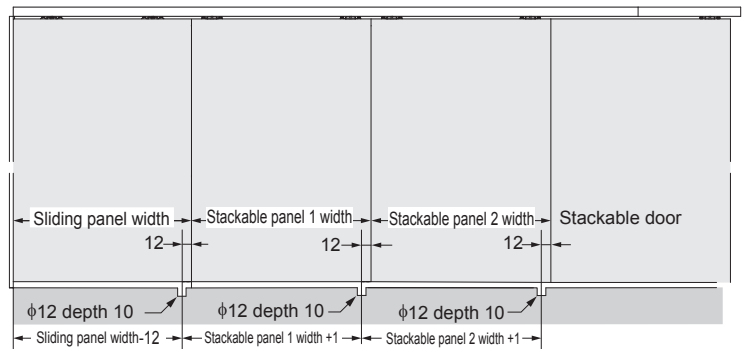
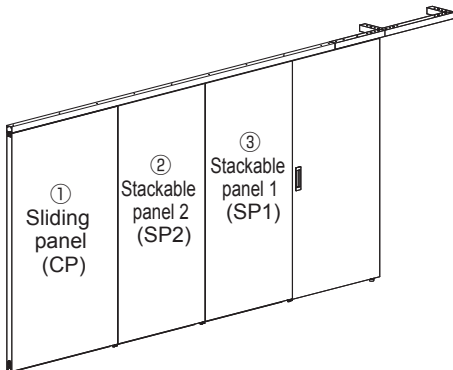

**[1]** Position the strike just below the center of upper track.

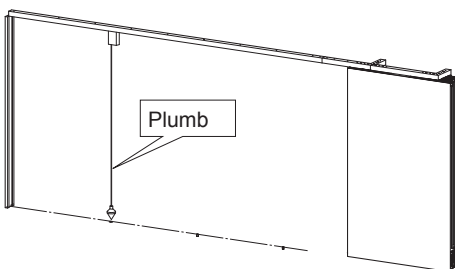

**[2]** Determine the position while closing the panel.

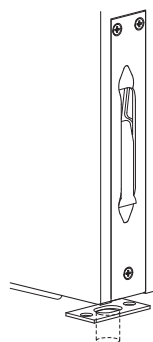

**[3]** Drill a hole on the floor.

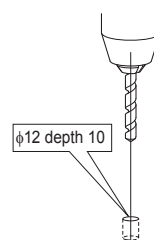

**[4]** Fix the strike with provided screws.

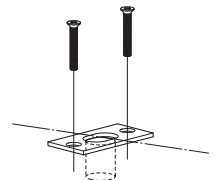

## 9 Mount Magnet Floor Guide Pin

### (1) Positioning

- Position the pin just below the center of upper track with plumb.

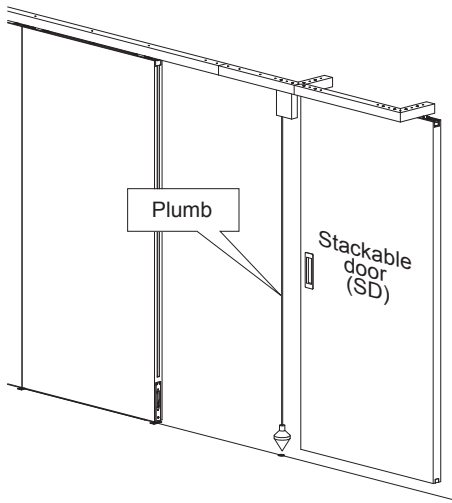

- Position

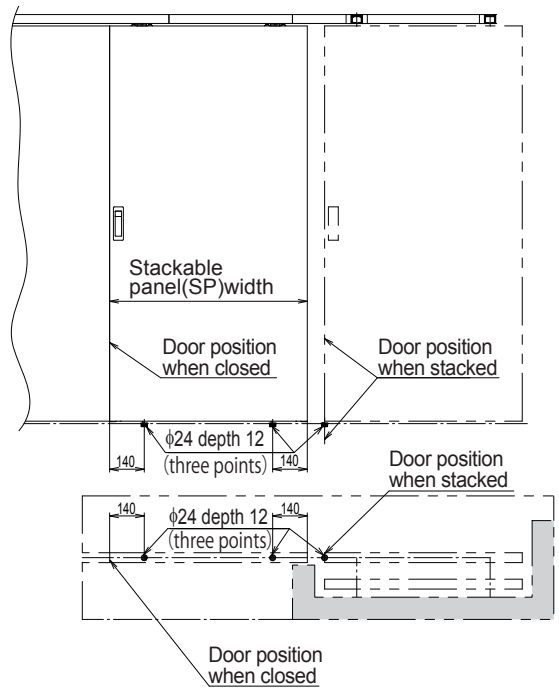

### (2) Hole processing

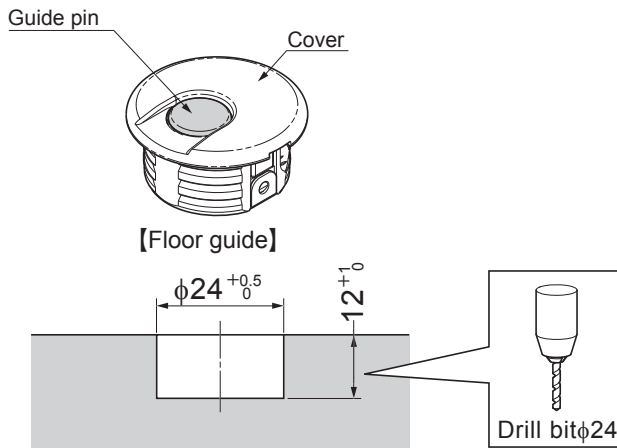

#### ⚠ Caution

The holes should be processed correctly to vertical status. After processing the holes, remove the chips from the hole.

### (3) Mounting floor guide

Do not fix floor guide with screws at this stage.  
(It will be fixed at procedure [6])

#### ⚠ Caution

The guide pin is likely to be damaged if hit with a hammer. If you have difficulties inserting the pin, use a wood block.

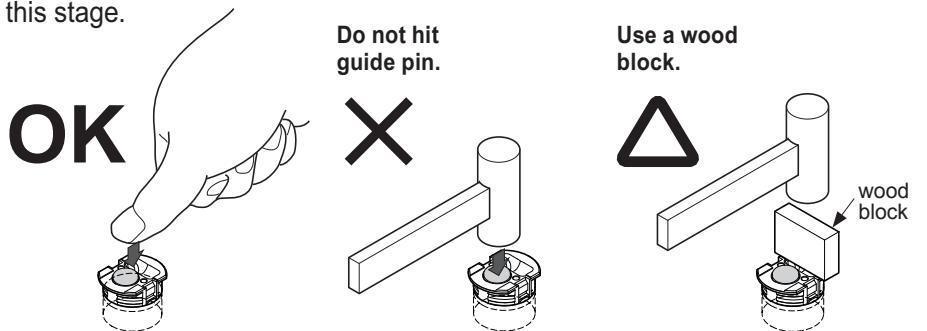



## [4] Setting height of counter plate for magnet floor guide

### <1> Lowering counter plate

- 1 Insert a screwdriver or the like.

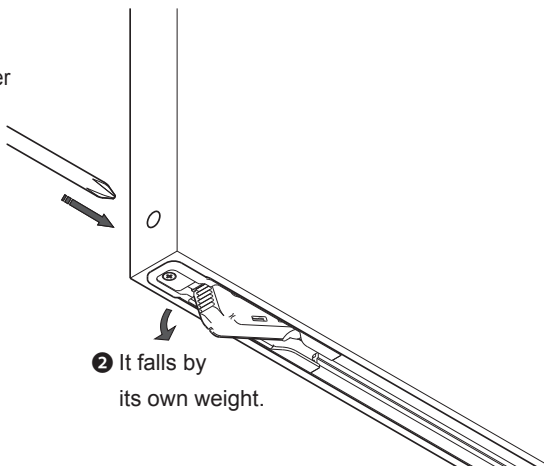

Carry out this procedure for every counter plate.

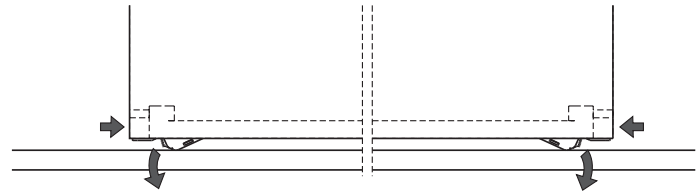

### <2> Automatic setting

Slowly slide the door to pass the floor guide, then the height of counter plate is automatically set.

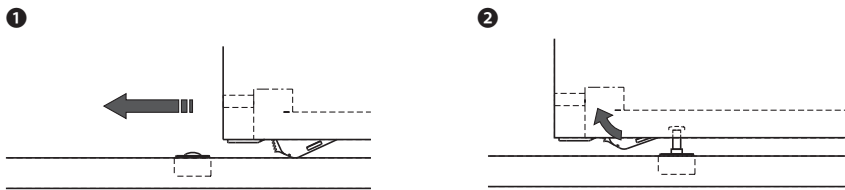

## [5] Operation check

Slowly slide the door to make it pass over floor guide. Even when the door is swung back and forth a little, the guide pin should be attracted by magnet and be drawn inside of counter plate. Confirm this movement.

If the above movement is not confirmed, adjust the direction of floor guide.

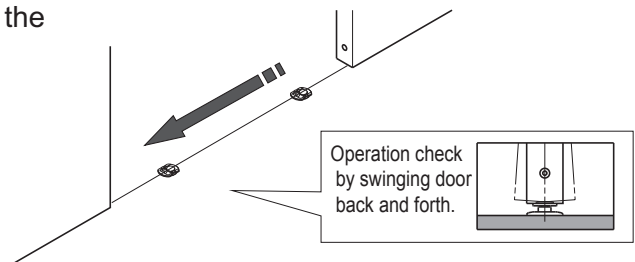

Range of adjustment

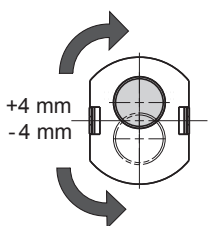

Special tool (recommended)

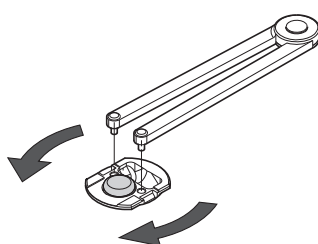

Spanner (take care not to scratch the floor.)

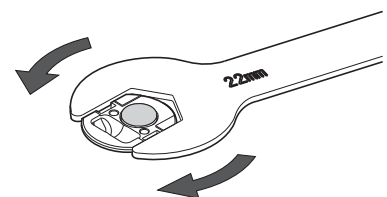

## [6] Fixing floor guide

① Fix with screws.

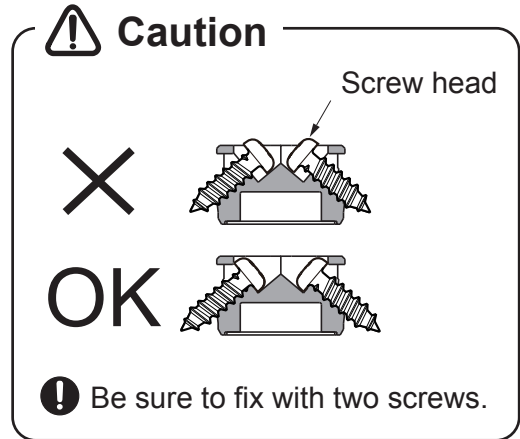
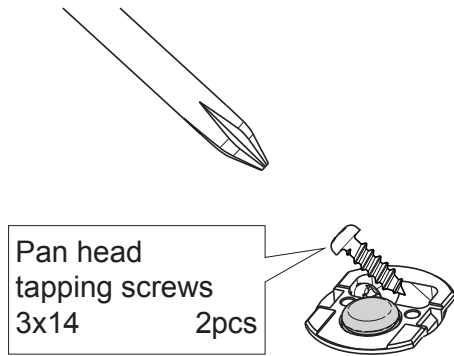

② Put the cover

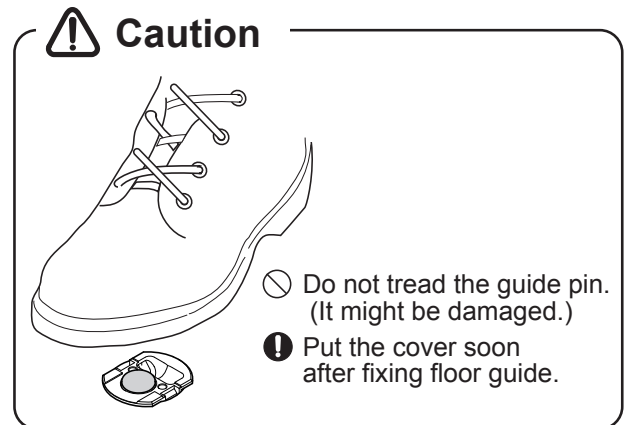
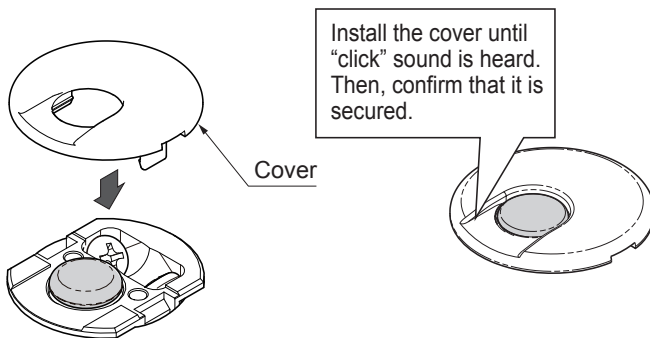

### [How to remove cover]

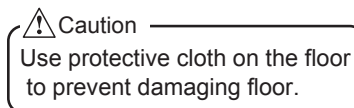
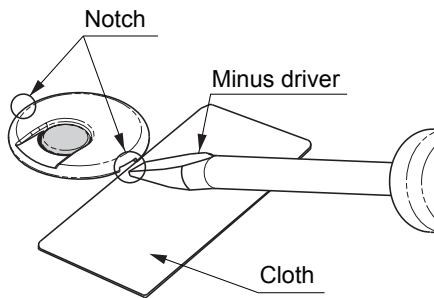

## [10] Adjusting door bottom tightner

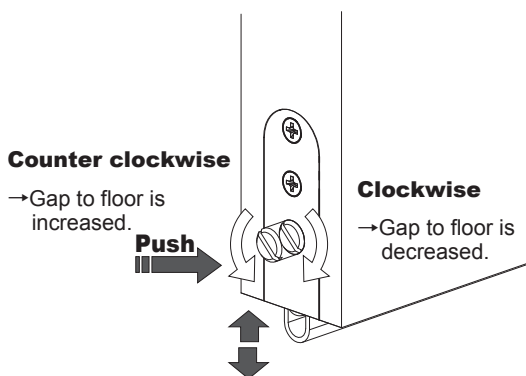

- Adjust the gap by turning the spindle on bottom tightner ⑬ .
- Check the gap also when the panel is locked with flush bolt.

# 11 Fixing sliding door stopper

## [1] Positioning

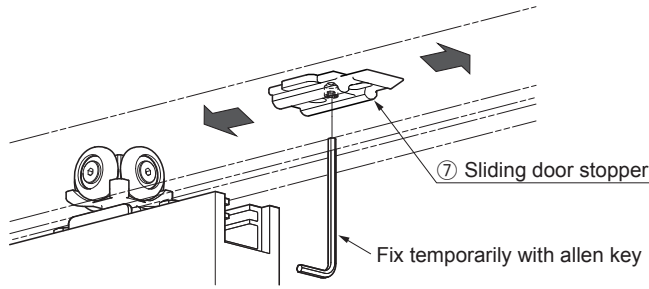

### ■ How to position

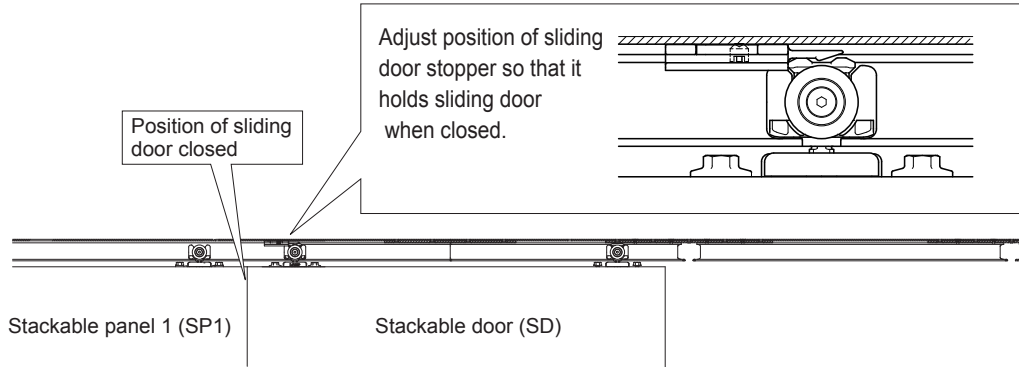

## [2] Hole processing on upper track

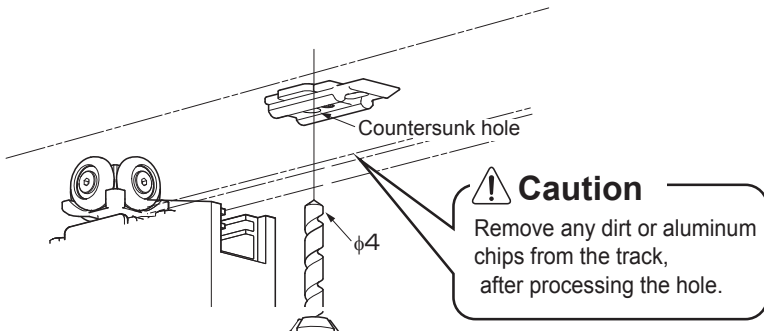



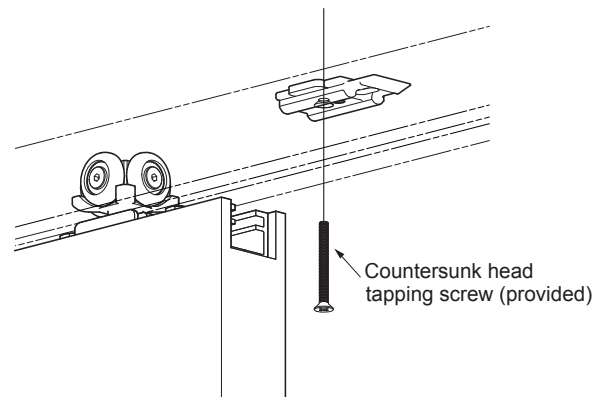

## [3] Fixing with screw

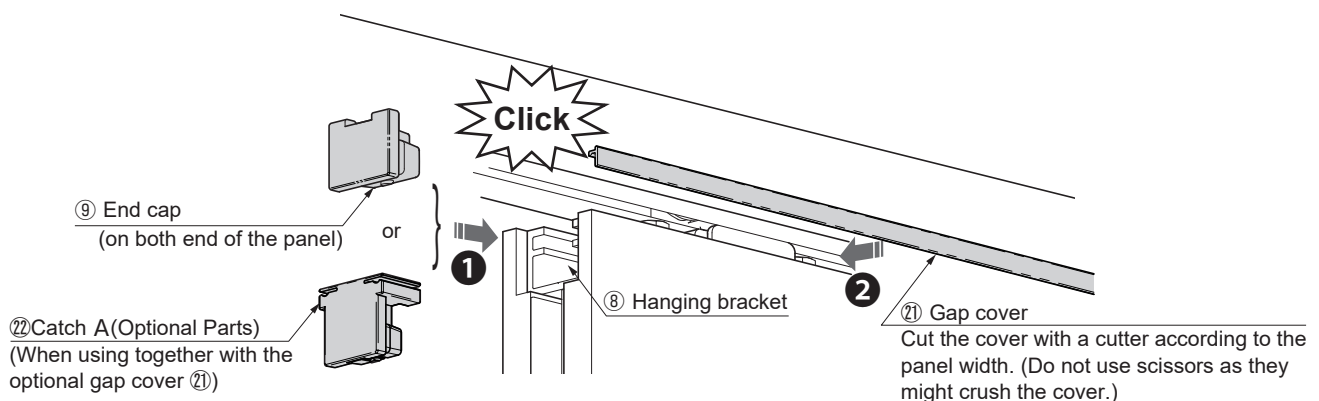

# 12 Mounting end cap or Catch A

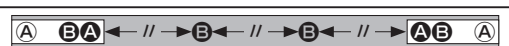

# Arrangement of Catch A and Catch B when installing a Gap cover (Per door)

Panel width	Hanging bracket length	Catch A  A A	Catch B  B		Mounting point (upper door opening)
			Next to upper roller	Center of panel	
500 ~ 700	240	4 pcs./Set	—	—	—
700 ~ 900	340		2 pcs. / per panel	—	
901 ~ 1150	340		2 pcs. / per panel	1 pc. / per panel	
1151 ~ 1300	340		2 pcs. / per panel	2 pcs. / per panel	

The (A) is the catch A to be installed at the end.

## TROUBLESHOOTING

TROUBLE	CHECK	SOLUTION
Panel does not go in stacking track.	Check if panel's recessed roller mount pitch deviates from stacking track.	Adjust recessed roller mount pitch. If recessed roller set bolt is loosened, retighten. Refer to "4 Assembling Recessed Rollers, Hanging Panels"
	Check if correct rollers are installed.	Recessed roller for sliding panel might be assembled wrongly to stackable panels. It is needed to replace recessed roller. Refer to "4 Assembling Recessed Rollers, Hanging Panels".
	Check if magnet floor guide stays in stackable door.	Adjust position of recessed rollers on stackable door so that the door will be released from floor guide when it is stacked. Refer to "4 Assembling Recessed Rollers, Hanging Panels".
Panel is caught during operation.	Check if fixing screw on upper track is loosened.	Recessed roller may contact to screw. Loosen the screw.
	Check if upper track is jointed to stacking track correctly.	The connecting part of upper track and stacking track should be connected with provided connecting plate, with no gap and no unevenness. Refer to "6 Mounting Upper Track"
	Check if recessed roller on stackable door and sliding door stopper are installed correctly.	Recessed roller of stackable door should be caught by the stopper on straight track. If recessed roller for stackable door on stackable panel is installed wrongly, replace recessed roller. Or, readjust the position of stopper. Refer to "4 Assembling Recessed Rollers, Hanging Panels".
Magnet floor guide does not work properly.	Check if magnet floor guide track and counter plate for magnet floor guide are installed at bottom of stackable door.	Confirm that all parts are installed. Confirm the order of door and panels. Refer to "2 [2] Magnet floor guide track, Counter plate for magnet floor guide".
	Check clearance between stackable door and floor.	The clearance between door and floor should be 10 mm. Adjust the clearance accordingly. Refer to "4 Assembling Recessed Rollers, Hanging Panels".
Abnormal sound when sliding panels.	Check if any dirt or aluminum chips remains in upper track.	Clean inside of upper track.
	Check rollers in the track for existence of aluminum chips.	Remove the track and remove rollers, then clean the roller.
	Check if the screw installing track to ceiling for looseness.	Retighten screw to avoid roller contact against screw.
Heavy movement of panel.	Check if panel contacts to the floor.	Confirm track fixing screws are not loosened. Readjust panel height so that clearance between panel bottom and floor becomes 10 mm.
Panels move automatically.	Check if upper track is installed horizontally.	Reinstall upper track horizontally with level gauge.
No response of floor guide pin during sliding	Check if dirt is caught at floor guide pin.	Dirt on guide pin causes poor performance of guide pin. Raise the pin by finger, then remove the dirt.
	Check if height adjustment of counter plate for magnet floor guide was done correctly.	Set height of magnet guide support, referring "9 [4] Setting height of counter plate for magnet floor guide".
	Check if clearance between door bottom and floor is set correctly.	When the clearance between door and floor becomes out of the range (10mm ±4mm), magnet floor guide does not work properly. Adjust the clearance.
Floor guide pin functions, but pin would not caught in the guide track.	Check if lower guide pin position was adjusted in correct manner.	Determine the position of floor guide pin, referring "9 [5] Operation check".
	Check if counter plate for magnet floor guide catches foreign matters.	Remove foreign matters.
Precautions when removing the door.	Confirm that door is free from floor guide pin.	While watching the floor guide pin not to be caught, loosen the tightening bolts on the rollers. Pull out rollers from the door.

**SUGATSUNE KOGYO CO., LTD.**  
Tokyo, JAPAN  
Phone: +81 3 3866 2260  
E-mail: export@sugatsune.co.jp

**SUGATSUNE KOGYO (UK) LIMITED**  
Reading, UK  
Phone: +44 1189 272 955  
E-mail: sales@sugatsune.co.uk

**SUGATSUNE EUROPE GmbH**  
Düsseldorf, GERMANY  
Phone: +49 211 53812 900  
E-mail: sales@sugatsune.eu

**SUGATSUNE AMERICA, INC.**  
California, USA  
Phone: +1 310 329 6373  
E-mail: sales@sugatsune.com

**Chicago, USA**  
Phone: +1 630 317 7072  
E-mail: sales@sugatsune.com

**SUGATSUNE CANADA, INC.**  
Montreal, CANADA  
Phone: +1 514 312 5267  
E-mail: support@sugatsune.ca

**SUGATSUNE SHANGHAI CO., LTD.**  
Shanghai, CHINA  
Phone: +86 21 3632 1858  
E-mail: lamp@sugatsune.com.cn

**Guangzhou, CHINA**  
Phone: +86 20 6639 3554  
E-mail: lamp@sugatsune.com.cn

**SUGATSUNE KOREA CO., LTD.**  
Incheon, KOREA  
Phone: +82 32 220 0603  
E-mail: sales@sugatsune-korea.co.kr

**SUGATSUNE KOGYO INDIA PRIVATE LIMITED**  
Mumbai, INDIA  
Phone: +91 9867299597  
E-mail: sales@sugatsune.in  
**Delhi, INDIA**  
Phone: +91 9867299597  
+91 11 45093636  
E-mail: sales@sugatsune.in