

LAMP® FD35EV SLIDING DOOR SYSTEM Installation Manual (Outset Type with Two-way soft close)

Part No. : FD35EVDHCP-AK

Thank you for selecting our product. Before starting installation, please read this manual thoroughly to ensure correct installation. Please keep this manual at hand for future reference.

ABOUT THE PRODUCT

- This is a parts set for a sliding door system for residential & commercial use.
- The door closes in a 2 soft motion steps; first slow, then fast, and opens with a 1 step soft motion.
- The door can be installed without the use of tools.

SPECIFICATIONS

Max. Door height	2400 mm
Max. Door width	590 – 1200 mm
Min. Door thickness	30 – 36 mm
Max. Door weight	35 kg ※ ¹
Vertical adjustment	3 mm upward, 4 mm downward
Front-rear adjustment	± 2 mm

- The closing speed of the soft closing type door may change due to ambient temperature, operating method or installation quality.
- Recommended ambient temperature range is 5 to 40°C.

※¹ When using a light weight door, you may feel the resistance of the soft closer when opening the door.

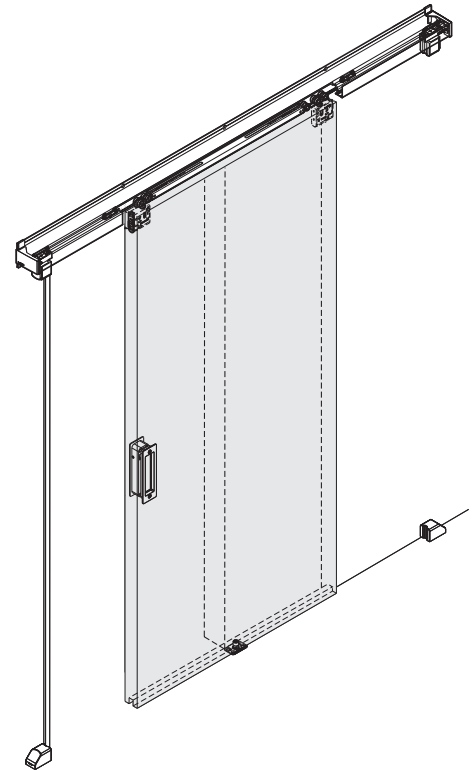

FOR YOUR SAFE WORK AND CORRECT INSTALLATION

Meaning of symbols

 Warning Caution	 Prohibited	 Required
--	---	---







WARNING: If not followed, death or serious injury may result.

- ❗ This product should be installed by a qualified person in accordance with this manual. If it is not installed correctly, the door may fall and cause injury.
- ❗ Provide a frame that can withstand the weight and impact of opening and closing the door. Be sure to use the specified screws and tighten them securely. If the mounting strength is insufficient, the door may fall and cause injury.
- ⊘ Do not use this product for any other purpose, or with doors that are outside the specifications of this manual.
- ⊘ Do not disassemble or modify any parts other than those described in this document.

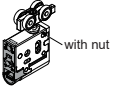
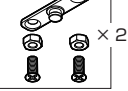
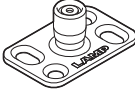

Caution: If not followed injury or damage may result.

- ❗ Follow the specified dimensions, specifications, and alignment of the door and frame. Warping, tilting or twisting of the frame or door may cause failure.
- ❗ If cutting any parts, make sure to remove any burrs before installation. Also check the upper track for any left-over burrs or scraps and remove these.
- ❗ This product is a part for architectural fittings. After installation, please check the function and safety of the final product. Please inform the end user how to use the product safely.
- ❗ Make sure to check the screws for slack at regular intervals (one month from first usage, half a year, and then one time every year is recommended).

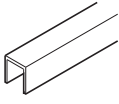

COMPONENT PARTS

No.	①	②	③	④	⑤	⑥	⑦	⑧
Name	Upper track	Soft Closer (two-way)	Upper roller	Outset Trigger	Lower guide (with Roller)	Door stopper (for Upper Track)	Door stopper (Floor Mount)	Side cover
Item No.	FD35EV-TRA	FD35EV-WRH-DSC	FD35EV-WRH-N	FD35EV-TRA-TRG	FD50-BGR18	FD35EV-TRA-STP	FD35EV-FSTP	FD30-HASC
Item	2120 / 2420 / 2720 mm Hole pitch: 300 mm Pitch end: 10 mm  1 pc	 1 pc	 with nut 1 pc	 × 2 1 set	 1 pc	 2 pcs	 2 pcs	 L/R 1 set
Accessory	Countersunk head tapping screw 4×40	Flat head tapping screw 3.8×40 3 pcs	Flat head tapping screw 3.8×40 3 pcs	Countersunk φ 6 head screw 4×10 4 pcs Nut M4 4 pcs	Countersunk head tapping screw 4×20 4 pcs	Pan head tapping screw 4×30 2 pcs pan head screw M4×12 2 pcs Nut M4 2 pcs	Pan head tapping screw 4×30 ... 3 pcs	Stopper plate Screw Countersunk head screw 4×25 (D6)

ACCESSORY : Spanner FD30-FSP

OPTIONAL PARTS	No.	⑨	⑩
	Name	Embedded Lower Guide Rail	Cover cap
	Item No.	FD30-HBRT1500SIL	FD30-WRH-CP
	Item	 Hole pitch: 250 mm Pitch end: 30 mm	 t=2
Remarks	Recommended screw: Countersunk head tapping screw 4×20	—	

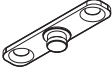
✗ The parts below which are packed with soft closer ② are not needed for this application.

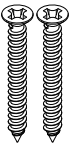
 Trigger
 Trigger Jig
 Countersunk head tapping screws 4 × 30 D6 : 2 pcs

INSTALLATION DRAWING (EXAMPLE)

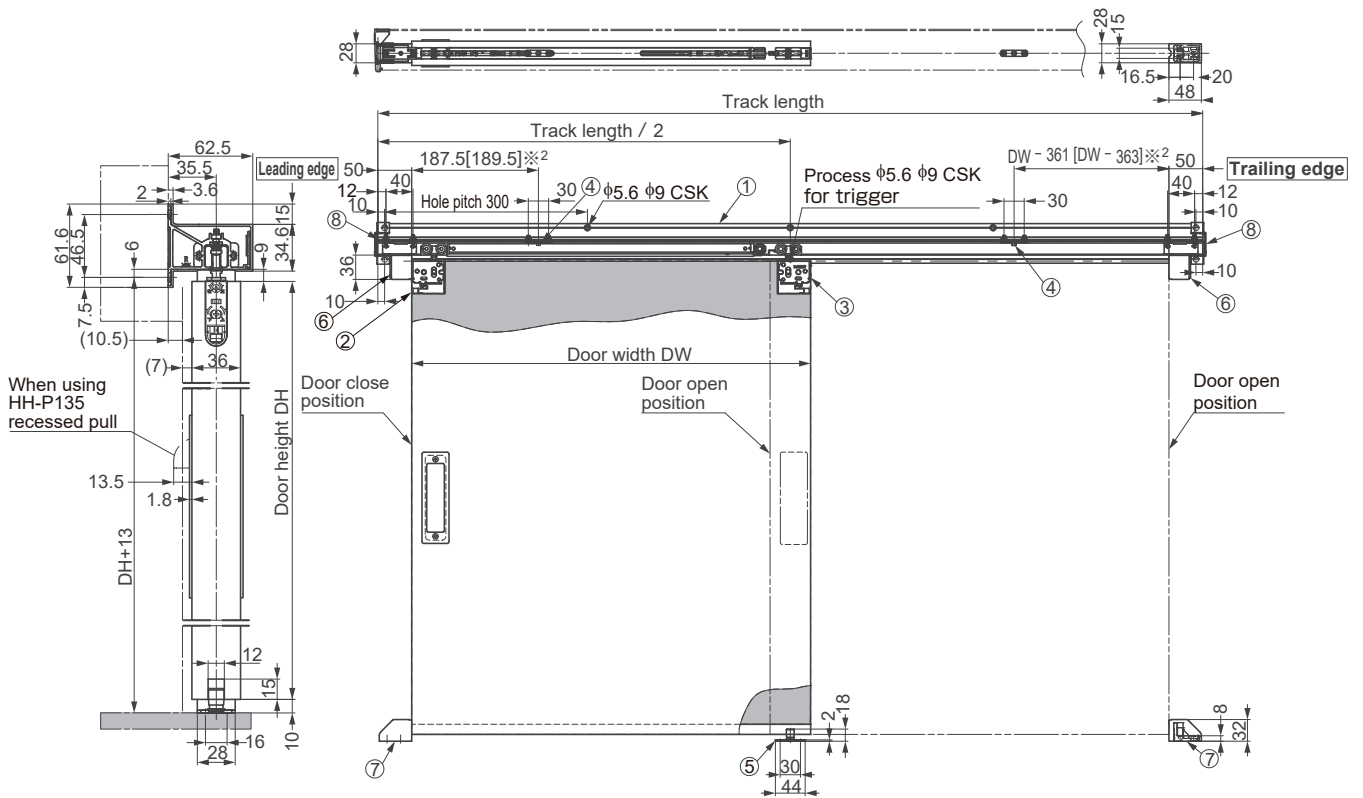

※ ² [] When Cover cap ⑩ (Optional parts) is used

Door process dimensions

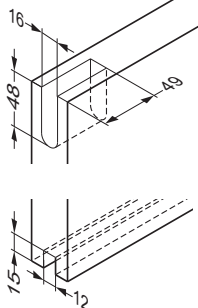

When cover cap is used (Optional parts)

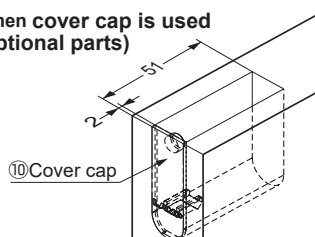

When embedded lower guide rail is used (Optional parts)

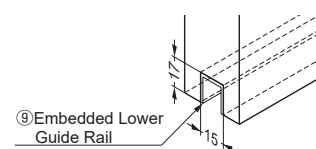

INSTALLATION PROCEDURE

1 Cutting and Hole Drilling on Upper Track

Cutting

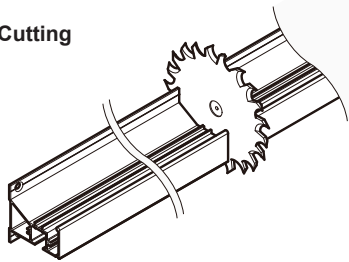

Hole processing

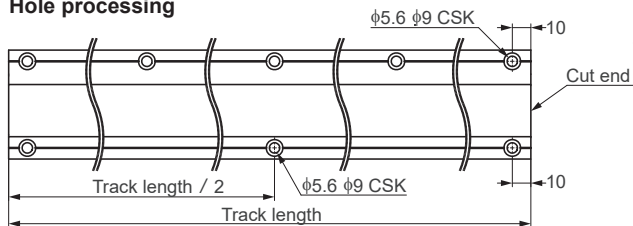

Processing holes for trigger

CAUTION
Take care of the direction of upper track (leading edge, trailing edge).

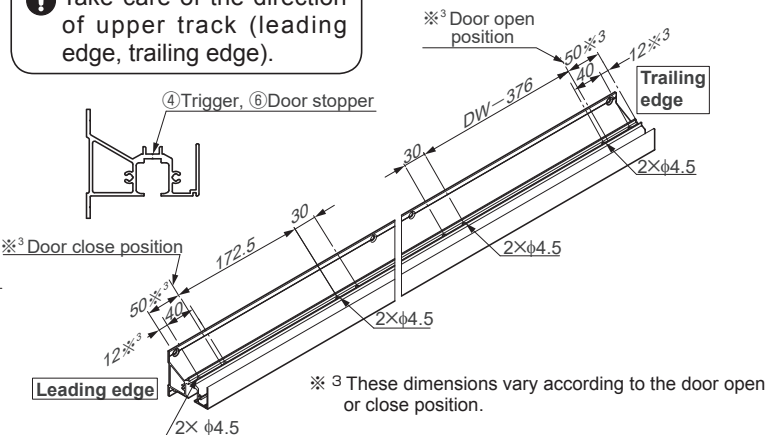

2 Mounting Parts on Door

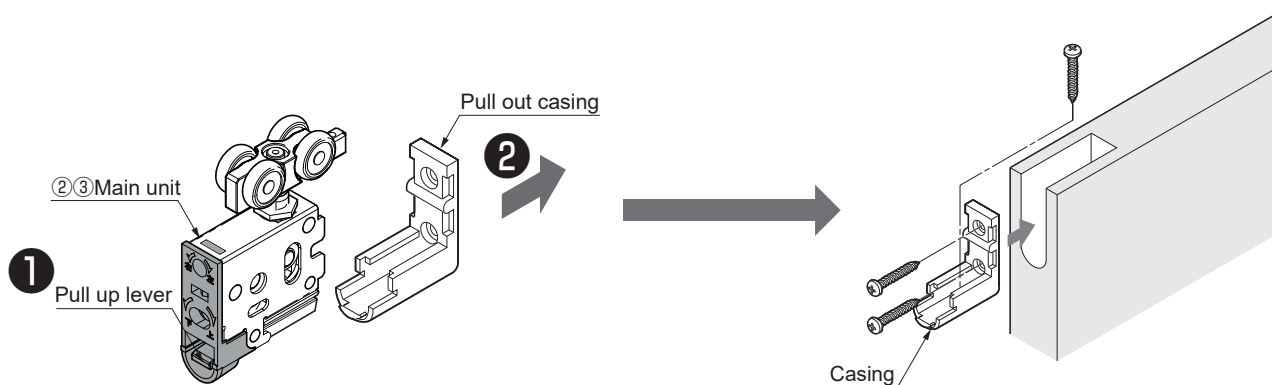

3 Verification Before Installing Soft Closer

CAUTION

Without verification the self closing feature may fail.

VIDEO LINK



If the trigger position is wrong, pull back the trigger catcher to the correct position using a 6 mm diameter round bar.

OK

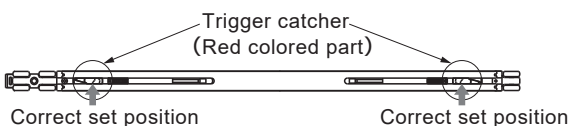

X

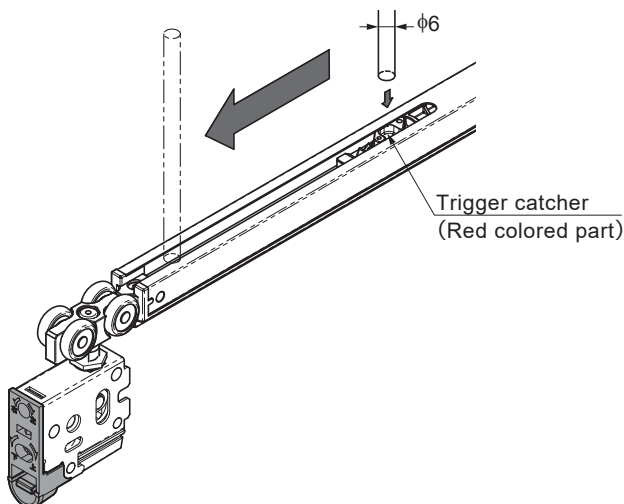
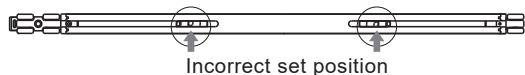

4 Inserting Parts into Upper Track

Insert the parts in order from ① to ④ with care of direction.

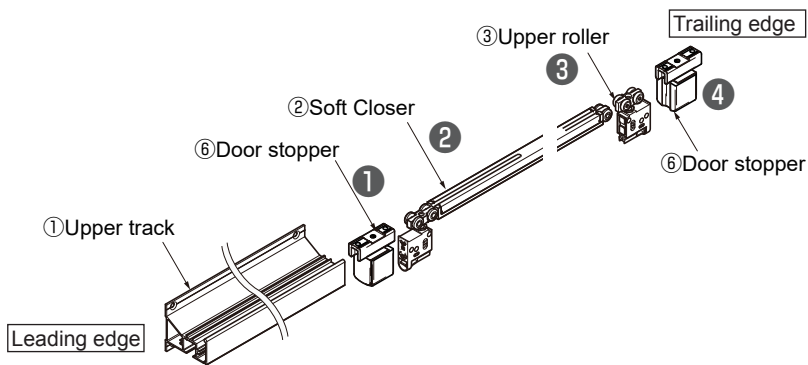

CAUTION

- ❗ Remove any dirt or aluminum chips from the track.
- ❗ Tape around rollers and upper track to prevent the inserted parts from falling.

5 Mounting of Upper Track

- ❗ **CAUTION**
- ❗ Verify that the upper track is set horizontally before fastening.
 - ❗ Remove any dirt or aluminum chips from the track.

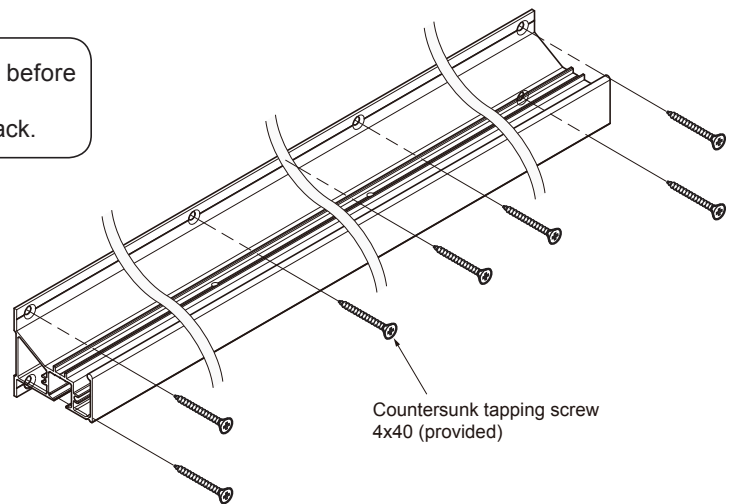

6 Fastening of Trigger and Door Stopper

Fasten triggers and door stopper to the hole made during procedure ① with the provided nuts.

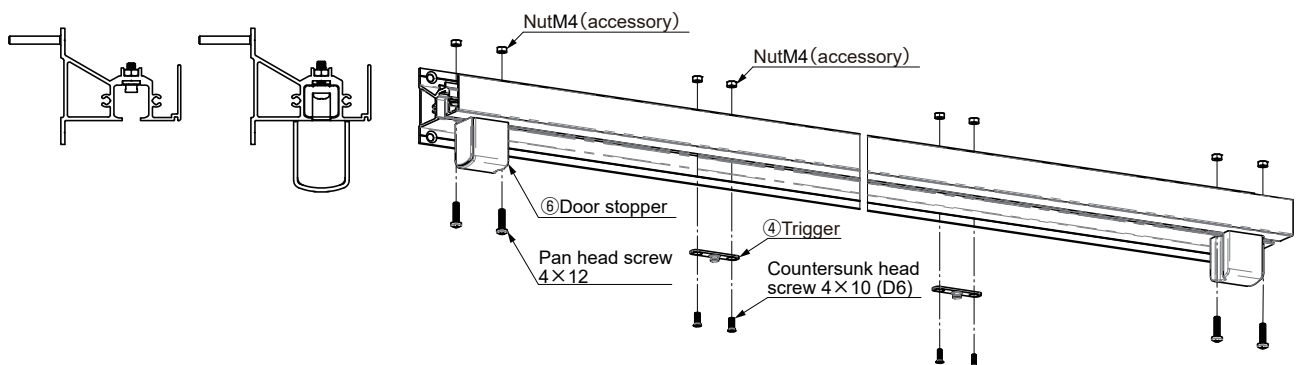

7 Assembly of Side Cover

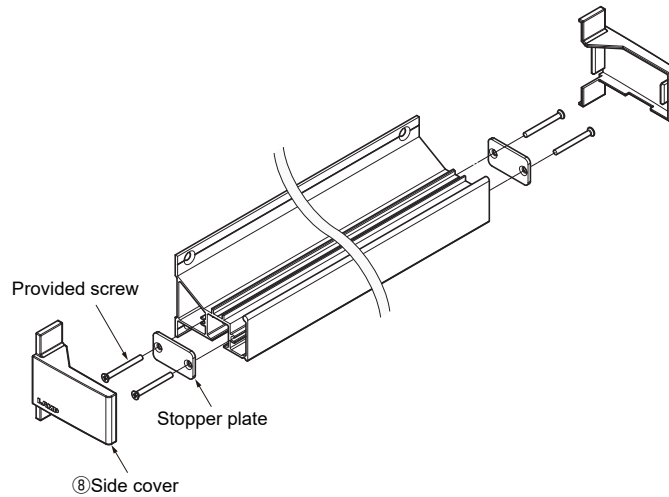

8 Mounting of Lower Guide Temporarily

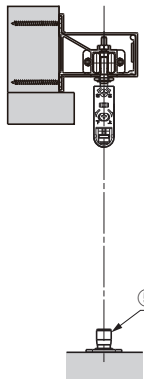

Position the lower guide below the center of the upper track so that it is covered by the door when it is opened and closed.

Temporarily fasten through the slotted holes with the provided screws.

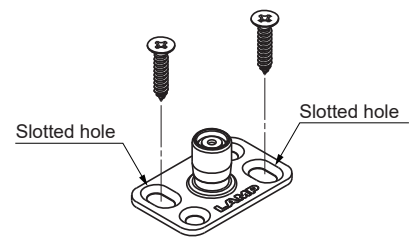
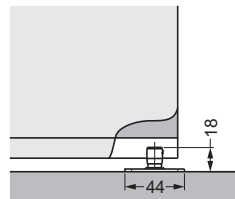

9 Hanging Door

- ① Place a 10 mm support under the door.
- ② While holding the door, place the groove under the door on the protruding part of the lower guide.

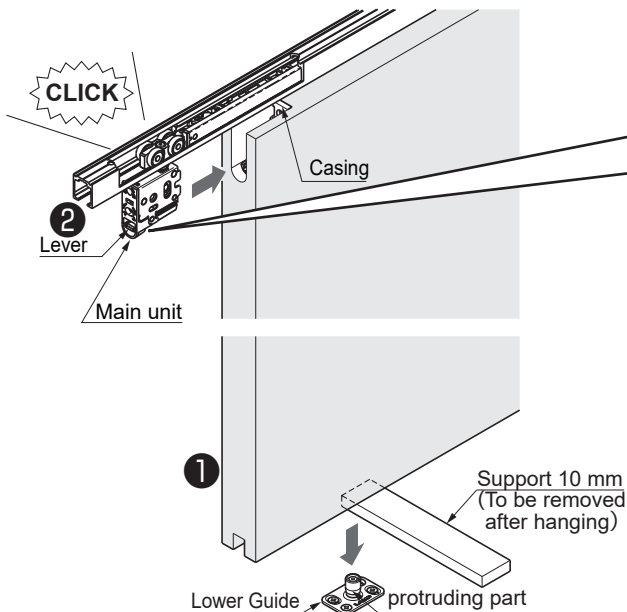

CAUTION
 Verify that the main unit is not dislocated from the casing, either of the door ends.

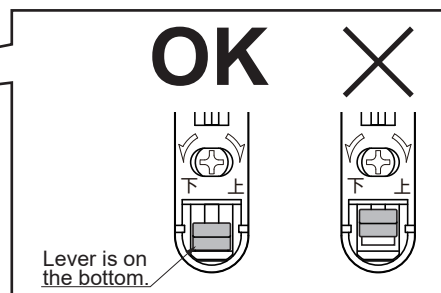

3 Verification of Soft Closer Operation

- Starting point of soft - close.
 Leading edge : approx. 100 mm before the stop position.
 Trigger edge : approx. 50 mm before the stop position.

10 Adjusting the Door Position

Adjust the door parallel to the upper track with 6-13 mm of clearance between the door and floor.

CAUTION

Do not turn the adjustment screw beyond adjustment range.

Do not turn adjustment screw beyond adjustment range.

Do not use electric screw driver.

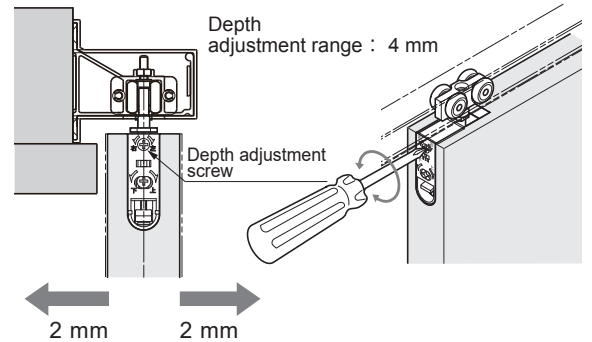
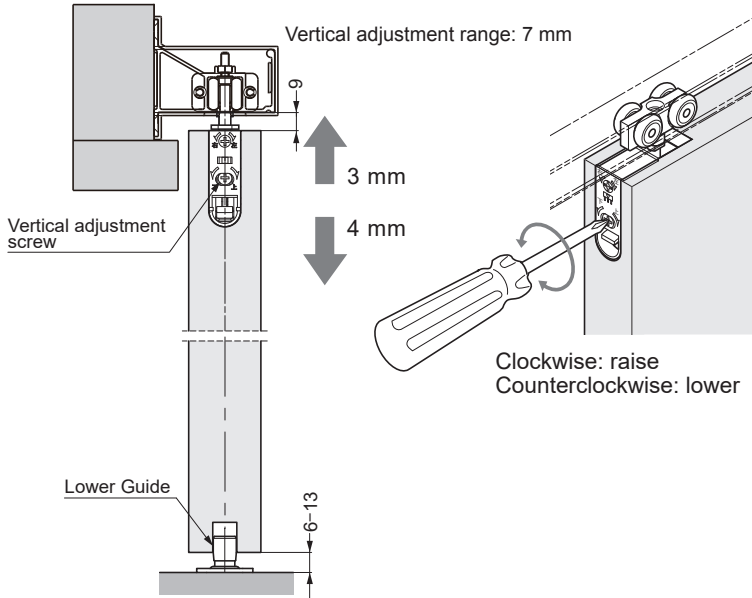
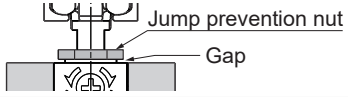

11 Adjusting, Fastening the Lower Guide

If the door movement is not smooth, remove the door, then adjust the lower guide forwards or backwards.

Fasten all 4 screws after the adjustment.

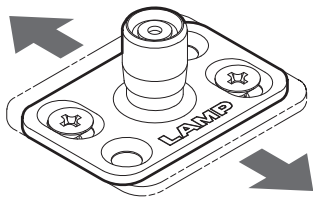

Adjustment range: ± 2 mm

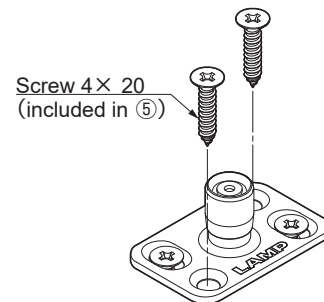

12 Fastening the Jump Prevention Nut

The jump prevention nut is on the hanger bolt of the upper roller.
Tighten the nut with the provided spanner until it contacts the soft closer.

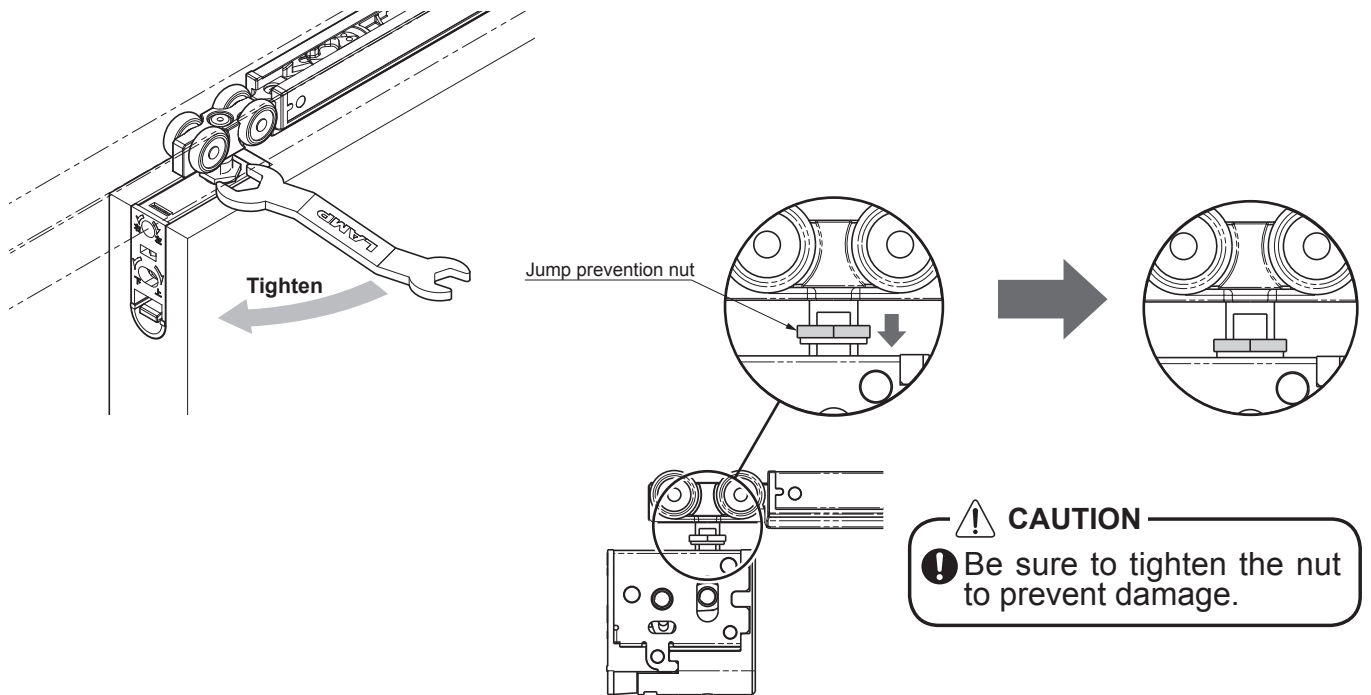

13 Mounting of door stopper (floor)

Fasten door stoppers at the positions where the door stops.

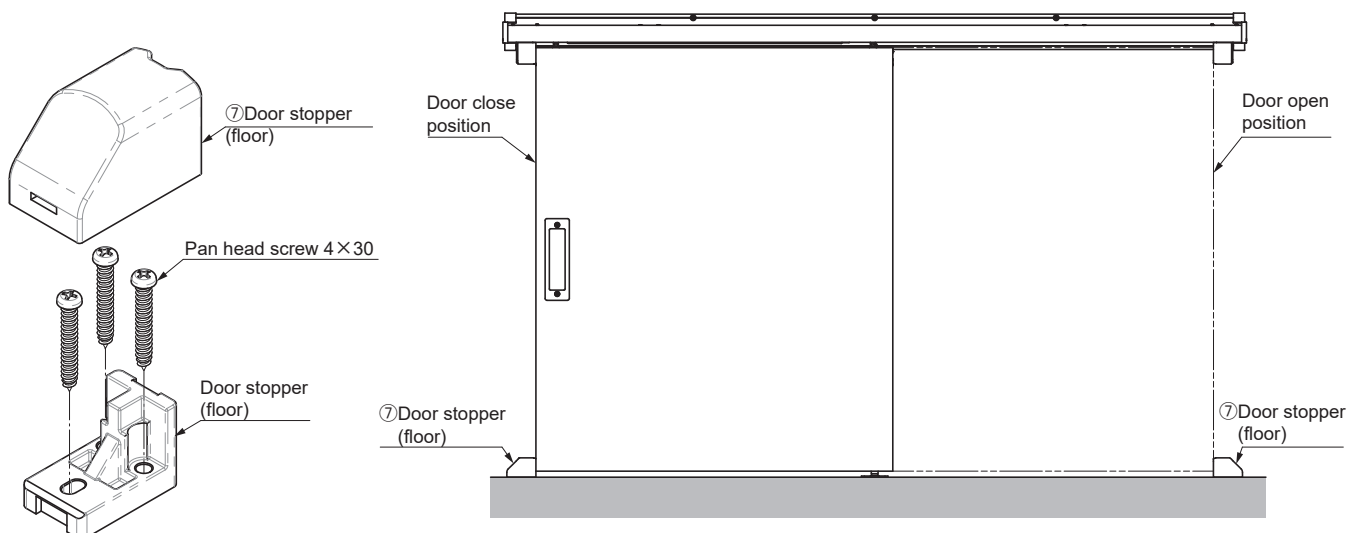

APPENDIX How to remove door

Use a 10 mm support under the door.

Then pull out the upper roller main unit from the door while raising the lever.

It will be easier if you slide the hanger bolt with a spanner.

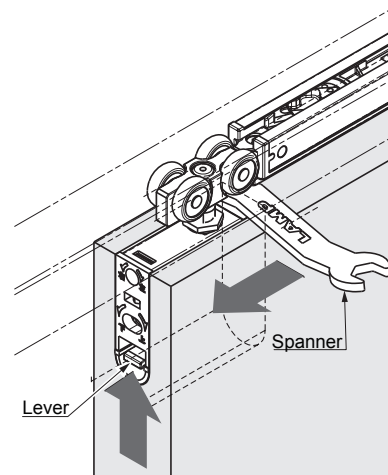

PERIODICAL INSPECTION

- Clean the inside of the track.
- Check the upper and lower space of the door. If necessary, correct the space.

TROUBLESHOOTING

Trouble	Checkpoint	Solution
Door stops during soft closing.	Check if door bottom contacts with floor or lower guide.	Verify that the track fixing screws are not loosened. Then, adjust the door height such that the clearance between the door bottom and floor is 6 - 13 mm.
	Check if upper track is set horizontally.	Using a level gauge, reset the upper track horizontally.
	Check if mohair seal is installed.	Reduce the friction between mohair and door.
The door doesn't close softly.	Check if trigger is installed.	Install trigger to specified position.
	Check if door is closed by excessive force.	Do not close door by excessive force as it may damage soft closer.
	The position of the trigger catcher in page 3 section 8 may become dislocated (It is hidden as installed in upper track.)	Slowly move the door toward the leading edge, then push the door firmly. Repeat this action on the opposite side as well. If it is still not improved, check the status of the trigger catcher in section 8.
Abnormal noise during operation	Check if door bottom contacts the floor or lower guide.	Adjust the door height such that the clearance between the door bottom and floor is 6 - 13 mm.
	Check if door touches adjacent parts.	Adjust the door depth position to avoid contact with other objects or adjust the position of lower guide.
	Check track rollers for aluminum dust.	Remove the track and pull out the roller. Then, clean the roller.
Heavy door operation	Check if door touches adjacent parts.	Adjust the door depth position to avoid contact with other objects or adjust the position of lower guide.
	Check if door bottom contacts the floor or lower guide.	Adjust the door height such that the clearance between the door bottom and floor is 6 - 13 mm.
Door starts to move.	Check if the upper track is set horizontally.	Using a level gauge, reset the upper track horizontally.

SUGATSUNE KOGYO CO., LTD.
 Tokyo, JAPAN
 Phone: +81 3 3866 2260
 E-mail: export@sugatsune.co.jp

SUGATSUNE KOGYO (UK) LIMITED
 Reading, UK
 Phone: +44 1189 272 955
 E-mail: sales@sugatsune.co.uk

SUGATSUNE EUROPE GmbH
 Düsseldorf, GERMANY
 Phone: +49 211 53812 900
 E-mail: sales@sugatsune.eu

SUGATSUNE AMERICA, INC.
 California, USA
 Phone: +1 310 329 6373
 E-mail: sales@sugatsune.com

Chicago, USA
 Phone: +1 630 317 7072
 E-mail: sales@sugatsune.com

SUGATSUNE CANADA, INC.
 Montreal, CANADA
 Phone: +1 514 312 5267
 E-mail: support@sugatsune.ca

SUGATSUNE SHANGHAI CO., LTD.
 Shanghai, CHINA
 Phone: +86 21 3632 1858
 E-mail: lamp@sugatsune.com.cn

Guangzhou, CHINA
 Phone: +86 20 6639 3554
 E-mail: lamp@sugatsune.com.cn

SUGATSUNE KOREA CO., LTD.
 Incheon, KOREA
 Phone: +82 32 220 0603
 E-mail: sales@sugatsune-korea.co.kr

SUGATSUNE KOGYO INDIA PRIVATE LIMITED
 Mumbai, INDIA
 Phone: +91 9867299597
 E-mail: sales@sugatsune.in
Delhi, INDIA
 Phone: +91 9867299597
 +91 11 45093636
 E-mail: sales@sugatsune.in