

Installation Manual

LAMP®

ALT-ST20-D360

POCKET DOOR SYSTEM (INSET) SOFT CLOSING

Thank you for selecting our product. Before starting installation, please read this manual thoroughly to ensure correct installation. Please keep this manual at hand for future reference.

ABOUT THE PRODUCT

- This product is hardware for vertical pocket doors in furniture, enabling slow door closing.
- The door is stored inside the cabinet.
- The door incline can be easily adjusted via a 5-stage angle retention mechanism.

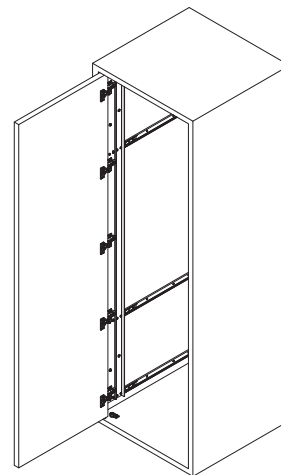

SPECIFICATION

Type	S	M	L	LL
Rail Q'ty	2	3	4	4
Door Width	Max. 600 mm			
Door Height	800 - 1200 mm	1200 - 1600 mm	1600 - 2000 mm	2000 - 2400 mm
Door Thickness	18 - 30 mm			
Door Weight	Max. 9 kg	Max. 15 kg	Max. 20 kg	Max. 20 kg

Item Name Guide



ALT - ST20 - D360S - 16

Type
Size of rail











FOR YOUR SAFETY AND CORRECT INSTALLATION

 Caution  Prohibited  Required

Caution If not followed, injury or damage may result.

- Provide a cabinet that can withstand the weight and impact of opening and closing the door. Be sure to use the specified screws and tighten them securely. If the mounting strength is insufficient, the door may fall and cause injury.
- Follow the specified dimensions, specifications, and alignment of the cabinet. Make sure that the cabinet is not warped, since it may affect the movement of the door.
- Position the handle so that the hand holding the handle does not strike the side board.
- When moving the cabinet, remove the door and re-assemble it at the site.
- This product is a part for furniture. After installation, check the function and safety of the final product.
- Make sure to check the screws for slack at regular intervals. (one month and six months from first usage and then once every year is recommended).
- **Be sure to inform users of the precautions below regarding opening and closing.**
 -  Do not force the door to open past 90°. Damage may result.
 -  When closing the door, pull it out until the catch clicks and then close it.
 - Repeated opening and closing may cause the inner rail to come off, shortening the door movement distance. Push the door fully inward or pull it fully out to correct the deviation.

COMPONENT PARTS/QUANTITY

				Inset (ST20-D360)				
				S Type	M Type	L Type	LL Type	
①	Rail※ ¹		 AL127C 16 - 28 inches	2	3	4	4	
②	Connecting plate	Connecting plate	 ALT-ST20-S ALT-ST20-M ALT-ST20-L ALT-ST20-LL	1	1	1	1	
		Adjustment bracket	ALT-ST20-LP	1	1	1	1	
③	Concealed hinge		 H360-D26-0T	2	3	4	5	
④	Hinge mounting plate		 360-P4W-30T	2	3	4	5	
⑤	Mounting plate		 ALT-MP30	2	3	4	5	
⑥	Guide roller		 ALT-GR	2	3	3	3	
Parts Set	⑦	Catch※ ²		 AL127-CH	2	2	3	3
	⑧	Roller		 DU19-B4SBR	2	2	2	2
	⑨	Roller bracket	ALT-2V-AB	1	1	1	1	
			ALT-2V-BB	1	1	1	1	
	⑩	Insert nut		 SC-107-13	2	2	2	2
	⑪	Slider		 G-175	2	2	2	2
	⑫	ALT-AB M5 Adjustment bolt			1	2	2	2
	⑬	Bind head tapping screw 3.5×15			18	27	34	34
	⑭	Bind head tapping screw 4×16			6	6	6	6
	⑮	Raised countersunk head tapping screw 3.5×15			4	6	8	10
⑯	Hexagon flange head screw M4×6			10	15	20	20	
⑰	Raised countersunk head screw M4×10			6	9	12	15	
⑱	Hex key			1	1	1	1	

※¹ Do not cut rails. Rail sizes (inches) include 16, 19, 22, 24, and 28.

※² This catch holds the door at the pulled-out position. Be sure to mount it on the uppermost and lower slide rails
(For details, see P.4 [3](#)).

DIMENSIONS: INSET ※Description is for left-handed product.

Rail Size	Door Storing	Cabinet Depth
16	269 + Door Thickness	412 + Door Thickness
19	345 + Door Thickness	488 + Door Thickness
22	421 + Door Thickness	564 + Door Thickness
24	472 + Door Thickness	615 + Door Thickness
28	574 + Door Thickness	717 + Door Thickness

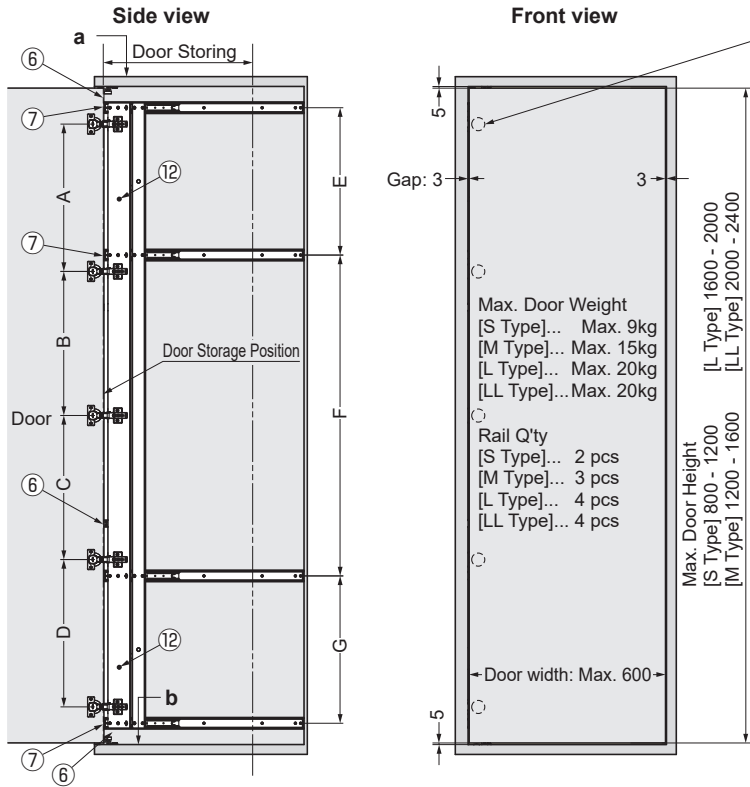

Type	Hinge pitch				Rail pitch		
	A	B	C	D	E	F	G
S Type	580	-	-	-	680	-	-
M Type	490	490	-	-	590	490	-
L Type	500	380	500	-	500	480	500
LL Type	450	440	440	450	450	980	450

Caution

- Make middle board removable for maintenance.
- Install a separately available door stopper for the leading edge.

Arrow b (for Insert nut)

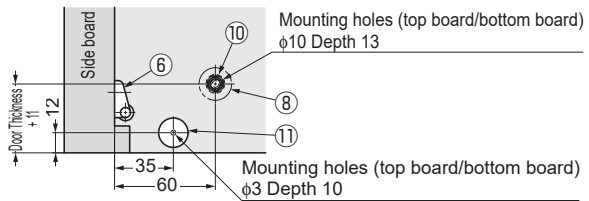

Arrow b (for Roller bracket)

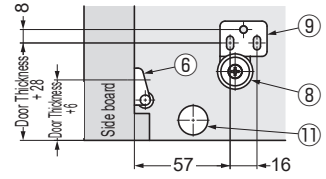

Fixed on the side board

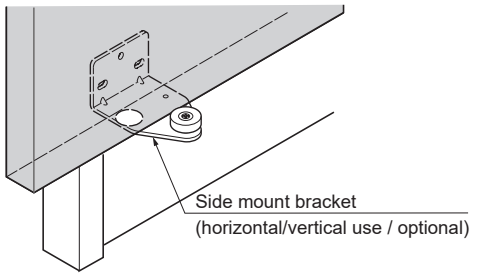

Item Name
ALT - BR

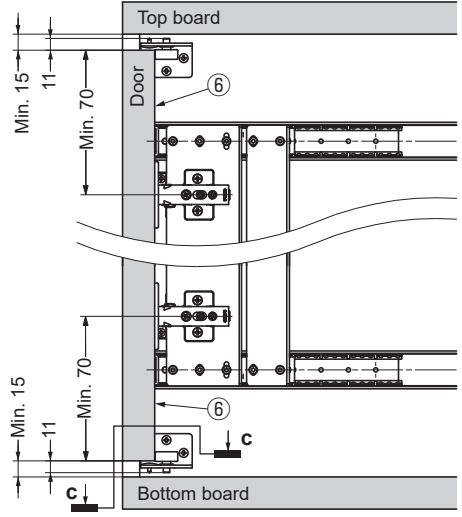
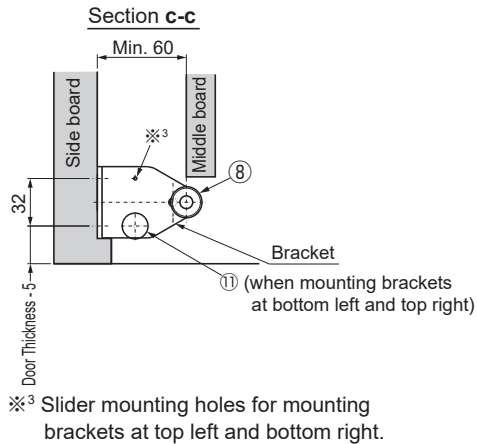

INSTALLATION PROCEDURE ※Description is for left-handed product, LL type.

1 Mounting the insert nut, roller, and slider

■ Fixed on the top and bottom boards

<Use roller bracket ⑨>

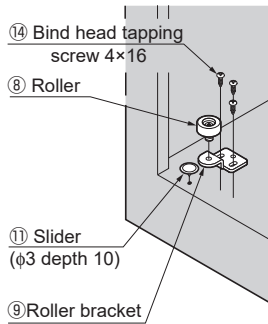

<Use insert nut ⑩>

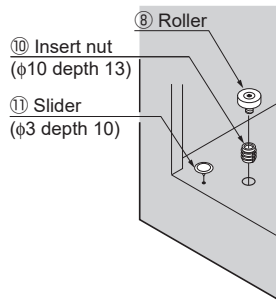

■ Fixed on the side board

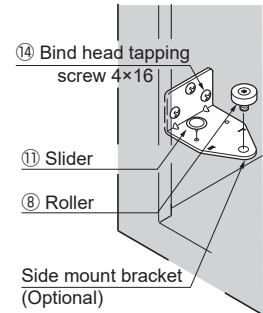

※Mount symmetrically on the top board as well.

2 Mounting the concealed hinge, hinge mounting plate, mounting plate, and slider

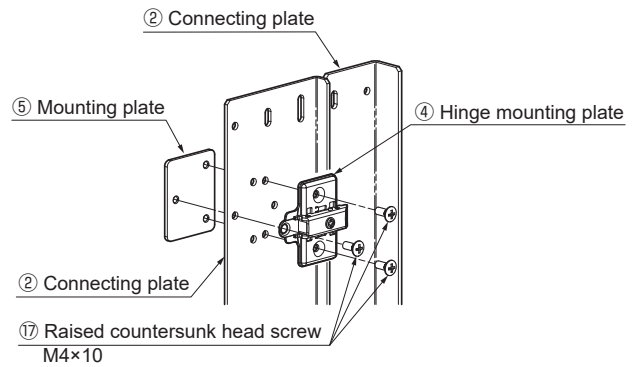
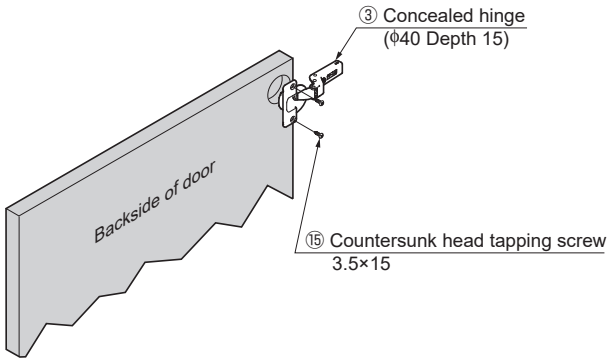

3 Temporarily fastening the slide rail and mounting the guide roller

1 Mount catch ⑦

⑦ Catch
Functions when pulled fully out.

Type	S	M	L	LL
Rail Q'ty	2	3	4	4
Catch Q'ty	2	2	3	3
Catch mounting location				
■ part				

2 Temporarily fasten all rail ends (outer and inner)

Screws: ⑬ Bind head tapping screw 3.5x15

3 Mount the guide roller

⑥ Guide roller

⑬ Bind head tapping screw 3.5x15

4 Temporarily fastening connecting plates

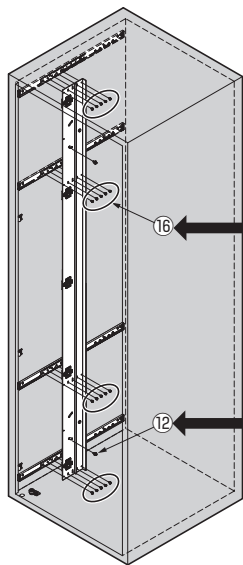

1 Temporarily fasten
all rails to connecting plates

Screws: ⑩ Hexagon flange head screw M4×6

2 Temporarily fasten
⑫ Adjustment bolts (1 - 2 pcs)

(After tightening, loosen 90° - 180°)

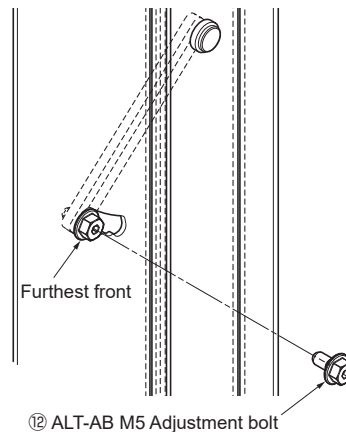

5 Rail fixing

1 Move the connecting plate from the front to the back, adjusting all the screw positions so that it moves smoothly

2 Tighten the ○ part (both ends)

3 Fasten all the ○ parts (near centre)

Screws: ⑬ Bind head tapping screw 3.5×15

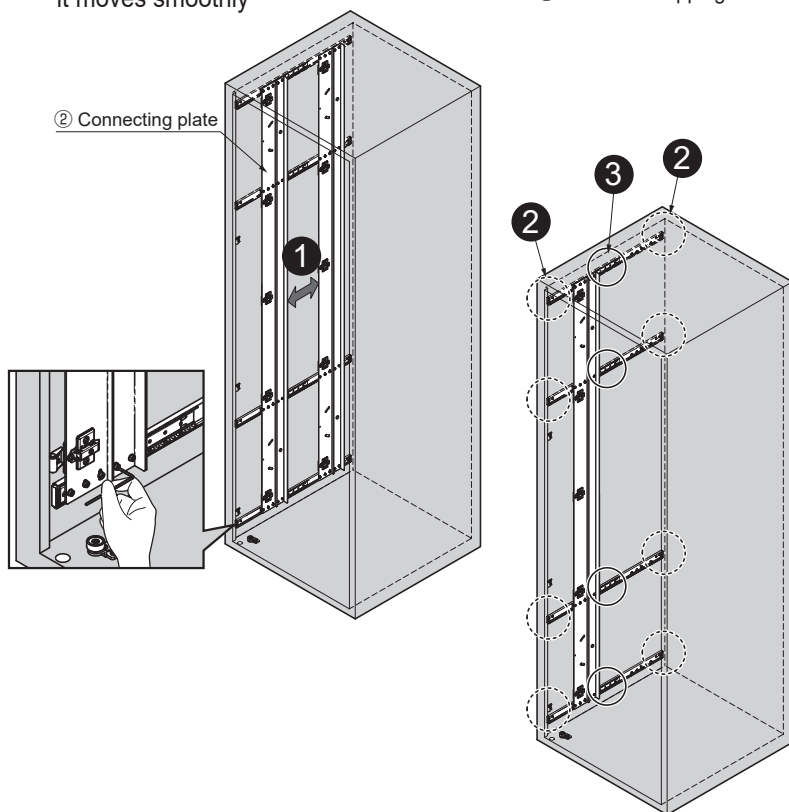

6 Hanging door

Push the hinge into the hinge mounting plate

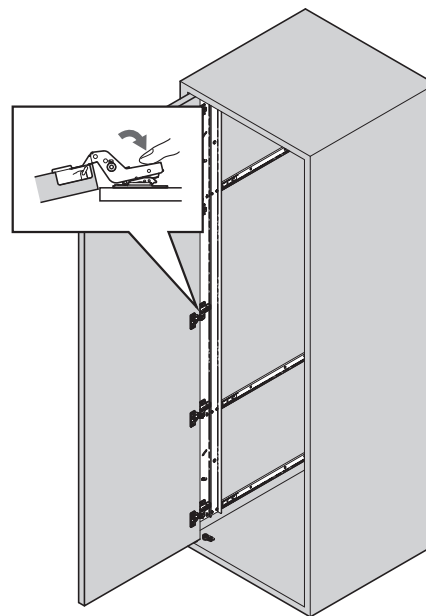

How to remove

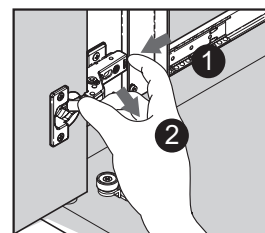

7 Adjusting the door

Adjustment method

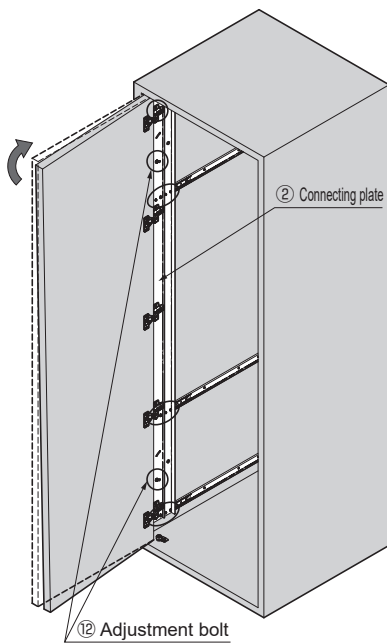

1 Check that the screws fixing the connecting plate and the adjustment bolts are loose.

2 Lift the door and shift the adjustment bolt backward one level at a time, to make the door and connecting plate vertical.

5-stage adjustment is possible in accordance with the door weight.

※When there are adjustment bolts at top and bottom, align their positions.

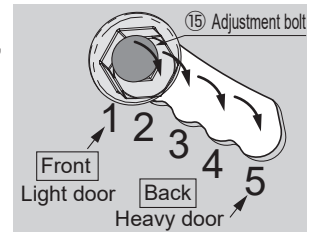

Before adjustment

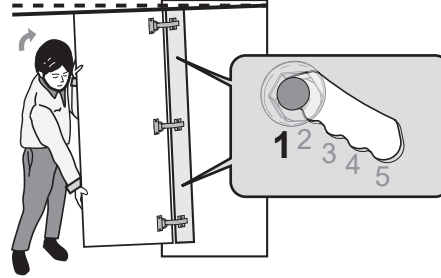

After adjustment

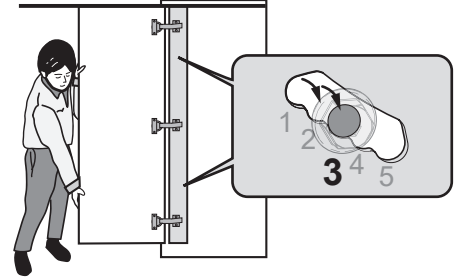

3 Tighten all the temporarily fastened screws

8 Door depth, vertical, horizontal, and closing speed adjustment

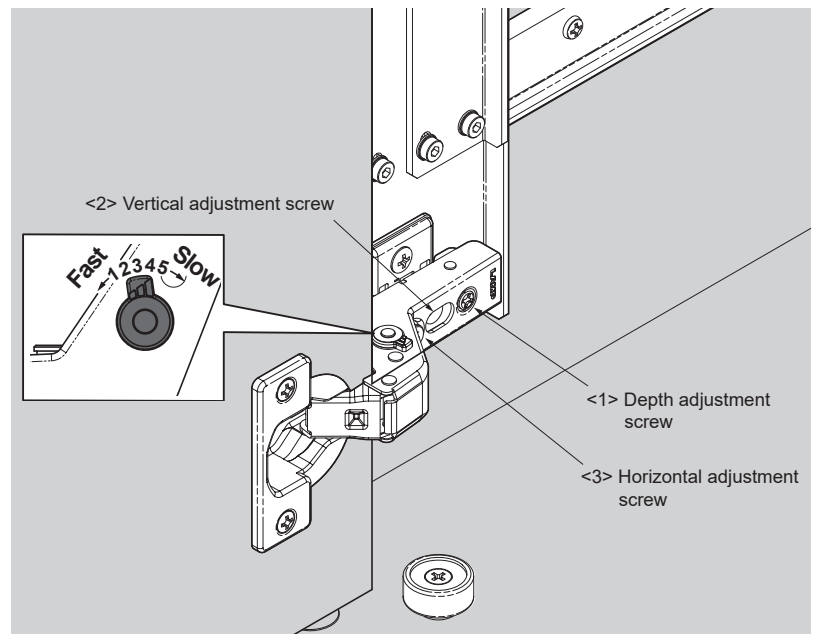
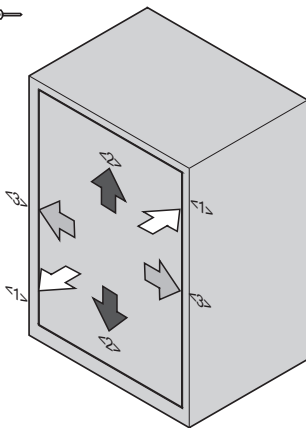

SUGATSUNE KOGYO CO.,LTD
Tokyo, JAPAN
Phone: +81 (0)3 3866 2260 E-mail:export@sugatsune.co.jp

SUGATSUNE KOGYO (UK) LTD
Reading, UK
Phone: +44 118 9272 955 E-mail:sales@sugatsune.co.uk

SUGATSUNE EUROPE GmbH
Düsseldorf, GERMANY
Phone: +49 211 53812900 E-mail:sales@sugatsune.eu

SUGATSUNE SHANGHAI Co., LTD
Shanghai, CHINA
Phone: +86 21 3632 1858 E-mail:lamp@sugatsune.com.cn

Guangzhou, CHINA
Phone: +86 20 6639 3552 E-mail:lamp@sugatsune.com.cn

SUGATSUNE KOGYO INDIA PRIVATE LIMITED
Mumbai, INDIA
Phone: +91 22 28314490/91 E-mail:sales@sugatsune.in

SUGATSUNE AMERICA, INC
California, USA
Phone: +1 310 329 6373 E-mail:sales@sugatsune.com

Chicago, USA
Phone: +1 630 317 7072 E-mail:sales@sugatsune.com

SUGATSUNE CANADA, INC.
Phone: +1 514 312 5267 E-mail:support@sugatsune.ca