

INSTALLATION MANUAL

LAMP®

FD35EVS

Moisture resistant two way close / Surface Mount Upper Roller Part No. : FD35EVS DHCMP

Thank you for using our product. Before installation, please read this manual thoroughly to ensure correct installation. Please keep this manual at hand for future reference.

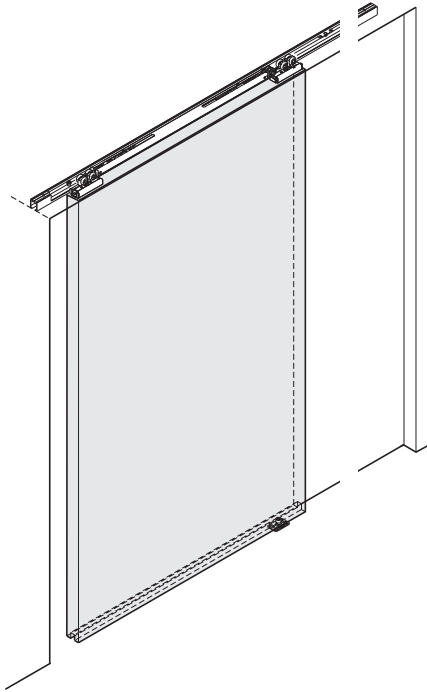

ABOUT THE PRODUCT

- Indoor top-mounted sliding door hardware, for use in living rooms or in places with high humidity, such as bathroom doorways.
- The closer works in both directions of opening and closing the door, pulling it in slowly and quietly.
- The door can be installed without the use of tools.

SPECIFICATIONS



Door height	Max.2400 mm	2401 – 2700 mm
Door width	590 – 1200 mm	700 – 1200 mm
Min. Door thickness	Min. 22 mm	
Max. Door weight	35 kg / door ※ ¹	
Vertical adjustment	2 mm upward, 4 mm downward	

- The closing speed of the soft closing type door may change depending on the ambient temperature, operating method or installation quality.
- Recommended operating temperature: 5°C – 40°C.
Recommended operating humidity: 45% – 95%RH.
- ※¹ When using a light weight door, you may feel the resistance of the soft closer when opening the door.



FOR YOUR SAFETY AND CORRECT INSTALLATION

 Warning ·  Caution  Prohibited  Required







Warning If not followed, death or serious injury may result.

-  • This product should be installed by a qualified person in accordance with this manual. If it is not installed correctly, the door may fall and cause injury.
- Provide a frame that can withstand the weight and impact of opening and closing the door. Be sure to use the specified screws and tighten them securely. If the mounting strength is insufficient, the door may fall and cause injury.
-  • Do not use this product for any other purpose, or with doors that are outside the specifications of this manual.
- Do not disassemble or modify any parts other than those described in this document.

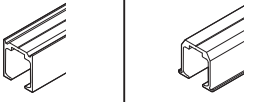
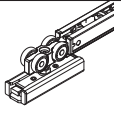

Caution If not followed, injury or damage may result.

-  • Cannot be used in sauna rooms, hot springs and beach areas, and other environments with a high risk of salt damage.
- The warranty does not cover defects caused by the use of detergents or high-temperature water that can affect resins or metals.
- The warranty does not cover the effects of water stain adhesion, condensation, seepage, mold, etc., or defects caused by freezing.
-  • Follow the specified dimensions, specifications, and alignment of the door and frame. Warping, tilting or twisting of the frame or door may cause failure.
- If cutting any parts, make sure to remove any burrs before installation. Also check the upper track for any left-over burrs or scraps and remove these.
- This product is a part for architectural fittings. After installation, please check the function and safety of the final product. Please inform the end user how to use the product safely.
- Make sure to check the screws for slack at regular intervals (one month from first usage, half a year, and then one time every year is recommended).
-  • This product is not waterproof. It cannot be used inside a bathroom where it may be directly exposed to water.

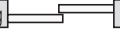
COMPONENT PARTS

No.	①		②		③		④
Name	Upper track (surface mount)	Upper track (recessed mount)	Soft closer (surface mount)	Spanner	Trigger	Trigger Jig	Upper roller (surface mount)
Item No.	FD35EV-TRM	FD35EV-TRH	FD35EVS-WRM-DSC	FD35EV-WRM-SP8	FD35EVS-TRG	FD35EV-TRJ	FD35EVS-WRM
Item	 <p>Hole pitch : 300 mm Pitch end : 30 mm Recommended screw: Countersunk head tapping screw 3.5 × 25 or Countersunk head screw M4 (D6)</p>		 <p>Accessory screw: Countersunk head screw 4 × 16 : 3 pcs Countersunk head tapping screw 4 × 40 : 3 pcs</p>		 <p>2 pcs</p> <p>Accessory screw: Countersunk head screw 4 × 16(D6) : 4 pcs Countersunk head tapping screw 4 × 30(D6) : 4 pcs</p>	 <p>1 pc</p>	 <p>Accessory screw: Countersunk head screw 4 × 16 : 3 pcs Countersunk head tapping screw 4 × 40 : 3 pcs</p>
Single sliding 	select		1 pc	—	1 set		1 pc
Double sliding 	select		2 pcs	—	2 set		2 pcs

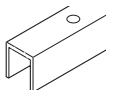
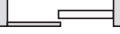
※ Use the mounting screws ②, ③, and ④ in accordance with the material to which they are to be attached.

No.	⑤	⑥
Name	Floor guide	Embedded Lower Guide Rail
Item No.	FD50-BG18	FD30HRBT type
Item	 <p>Accessory screw: Pan head tapping screw 4 × 16 : 5 pcs</p>	 <p>Hole pitch : 250 mm Pitch end : 30 mm Recommended Countersunk head tapping screw 4 × 25</p>
Single sliding 	1 pc	1 pc
Double sliding 	2 pcs	2 pcs

ASSEMBLY (In this manual, a single sliding door is used as an example.)

1 Cutting and Hole Drilling on Upper Track

⚠ Caution

❗ When cutting, reinforce the track to prevent deformation at the cut section.

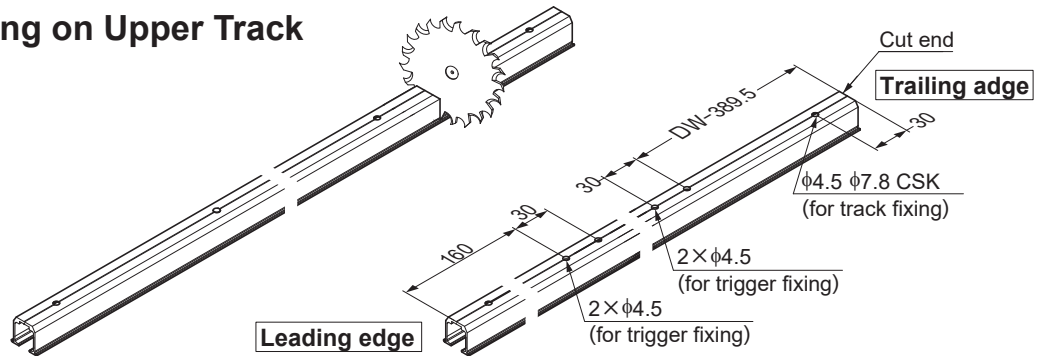

2 Mounting Parts on Door

1 Plug in

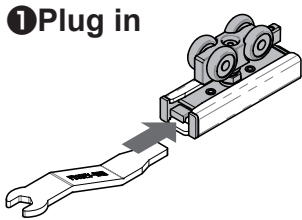

2 Push up

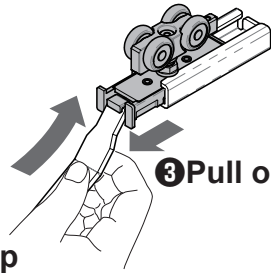

3 Pull out

4 Align the door end and the holder end and fasten

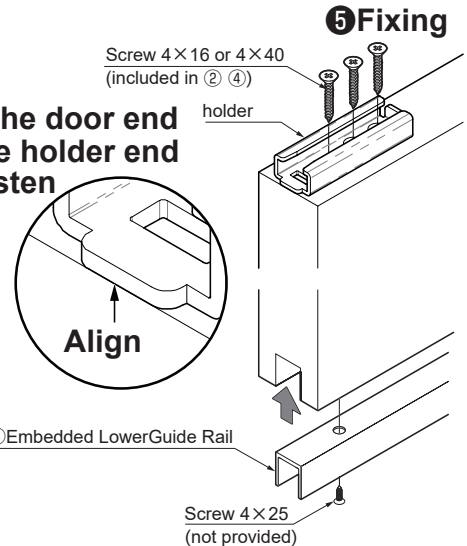

6 Embedded Lower Guide Rail

Screw 4 × 25 (not provided)

3 Verification Before Installing Soft Closer

Caution
 Without verification the self closing feature may fail.

If the position is wrong, pull back the trigger catcher to the correct position using a 6 mm diameter round bar.

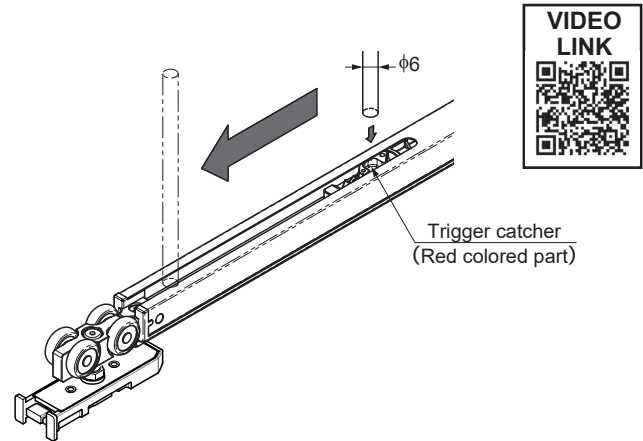
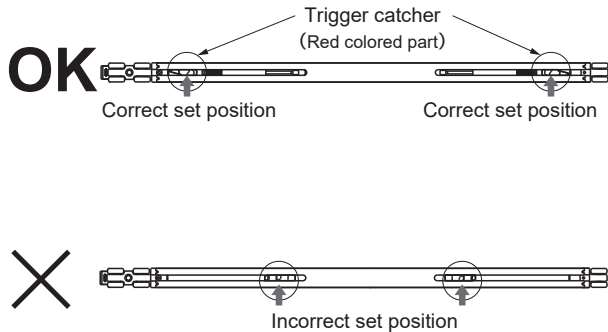

4 Inserting Parts into Upper Track

Insert the parts in order from 1 to 2 with care of direction.

Caution

- Remove any dirt or aluminum chips from the track.
- Fasten bumper blocks temporarily to prevent the inserted parts from falling.

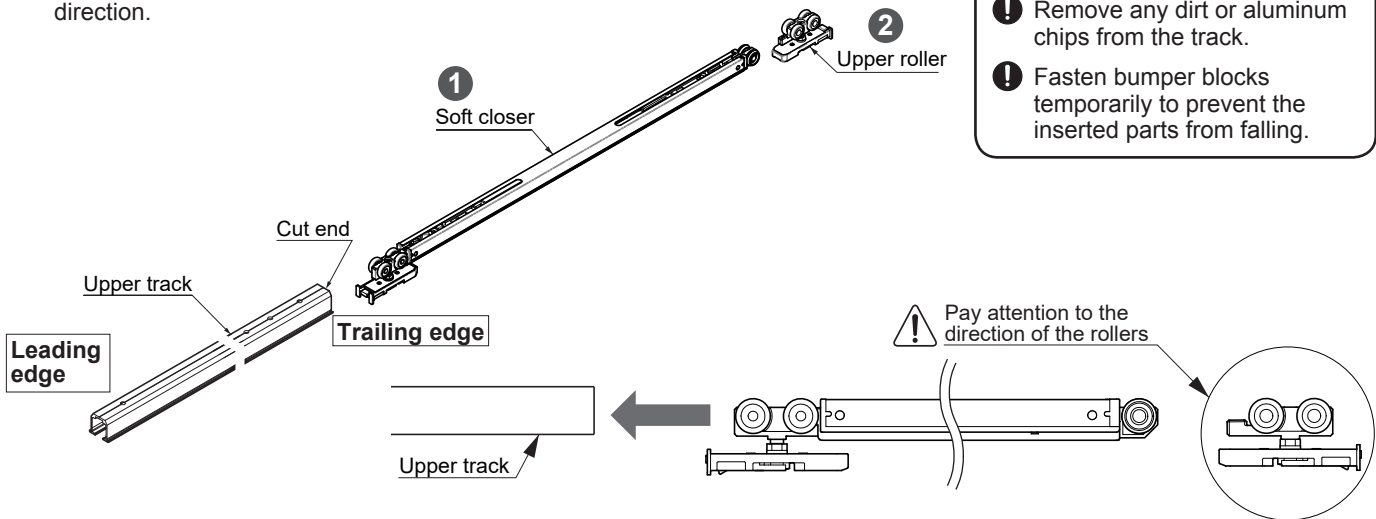

5 Mounting of Upper Track (Recommended screw: Countersunk head tapping screw 3.5×25 or countersunk head screw M4 head diameter Φ6: Customer order)

Caution

- Be careful not to overtighten the screws and screw heads protruding on upper track. It may cause deformation of track or damage of soft closer.
- Do not repeatedly attach and remove screws. This will weaken the joint and lead to protruding screws and rail sagging.

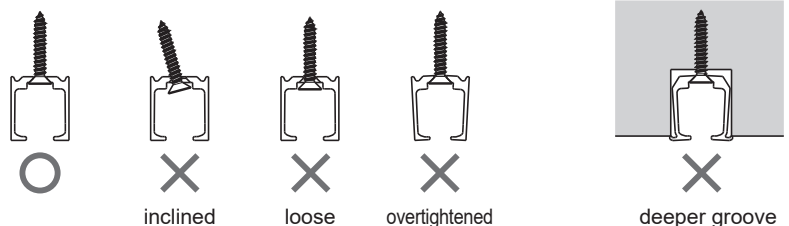

6 Fastening of Additional Trigger

Fasten trigger to the hole made during procedure 1 with provided screws.
The jig makes it easy to install the trigger.

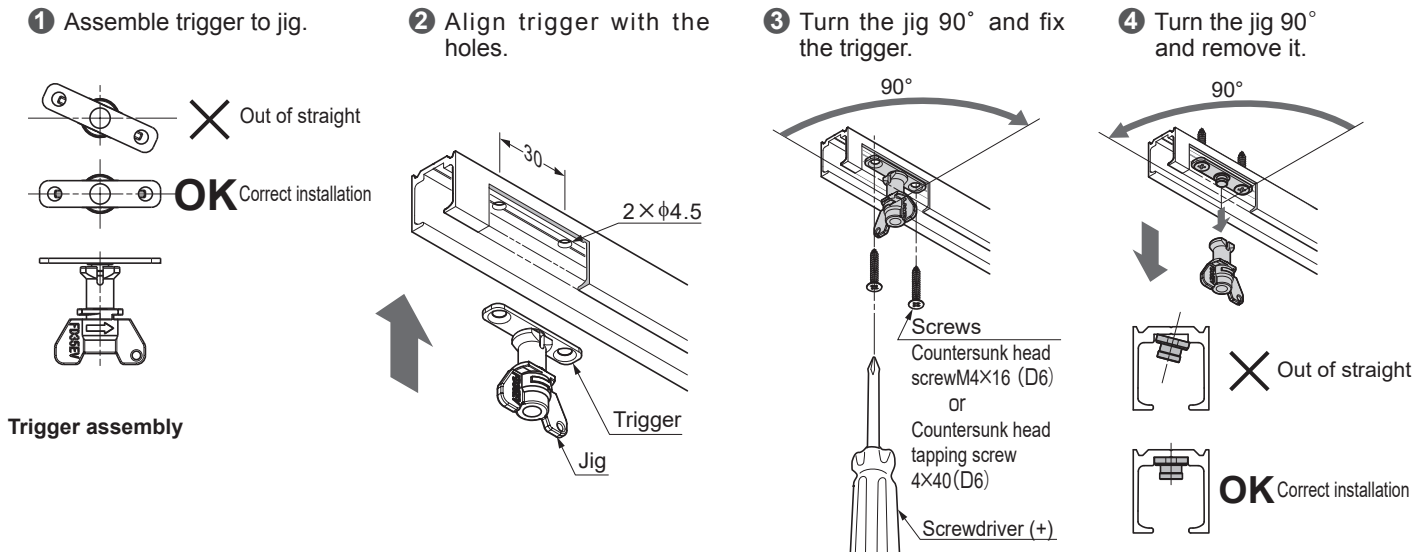

7 Mounting of Floor Guide Temporarily

Position floor guide just below the center of the upper track.

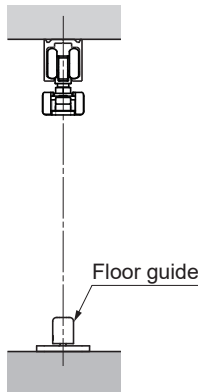

Temporarily fasten using the slotted holes with the provided screws.

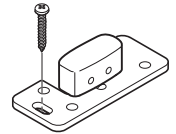
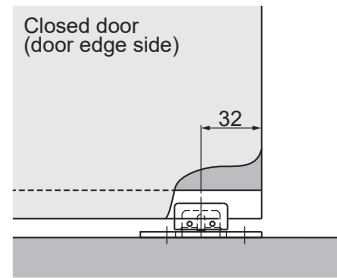

8 Hanging Door

1 Place a 10 mm support under the door.

2 While holding the door, place the groove under the door on the protruding part of the floor guide.

Caution

Verify that the main unit is not dislocated from the casing, either of the door ends.

3 Verification of Soft Closer Operation

Starting point of soft - close.

Start position: approx. 85 mm before the stop position

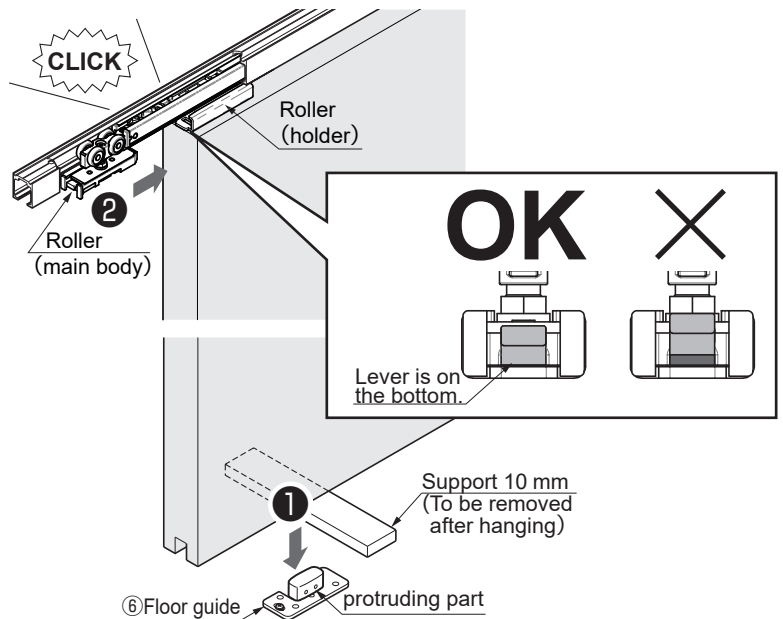

9 Adjustment of Door Height

Adjust door parallel to the upper track with 6 - 12 mm clearance between the door and floor.

⚠ Caution

- ⊘ Do not turn the adjustment screw beyond the adjustment range. It may cause damage

Adjustment range : 6 mm

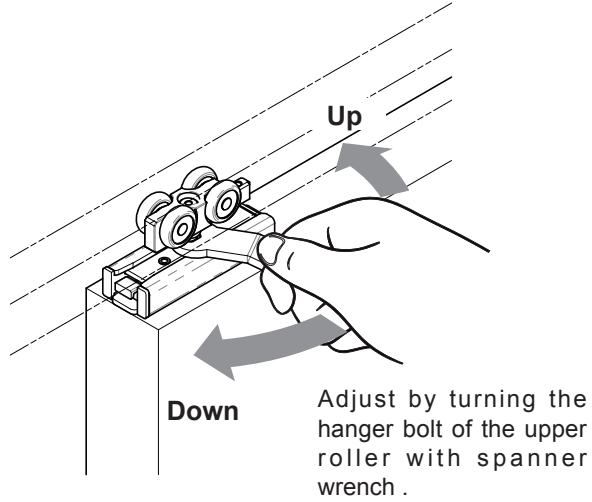
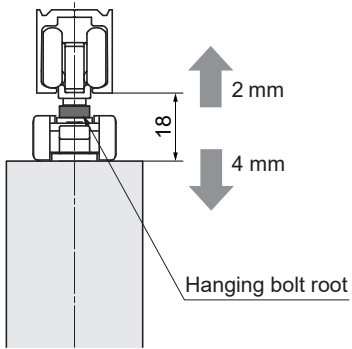

10 Adjusting, Fastening the Floor Guide

If the door movement is not smooth, remove the door, then adjust the floor guide forwards or backwards.

Tighten all four screws after the adjustment.

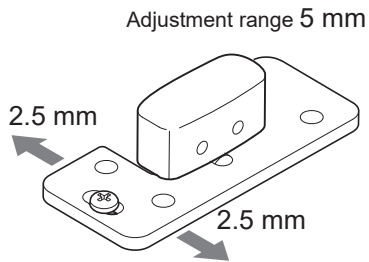

Pan head tapping screw 4 × 16
(Included in lower guide)

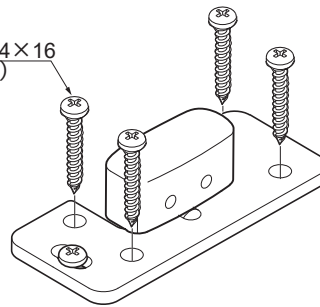

Appendix 1 How to remove door

Use a 10 mm support under the door.

⚠ Caution

⚠ Pay attention not to let the door fall.

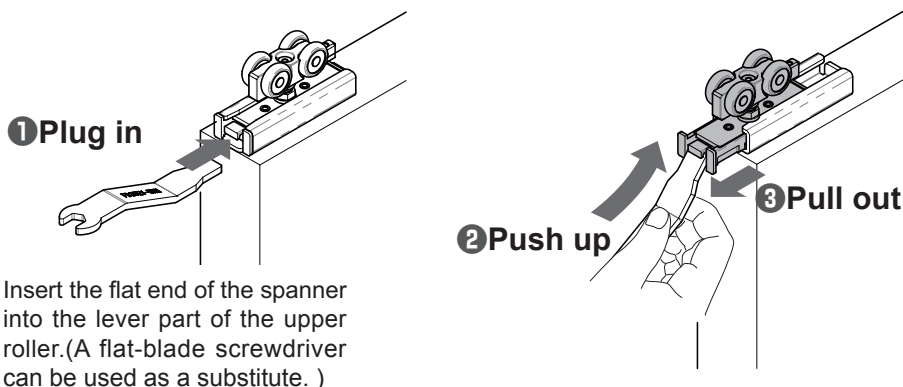

PERIODICAL INSPECTION

- Clean the inside of the track.
- Check the upper and lower space of the door. If necessary, correct the space.

TROUBLESHOOTING

Trouble	Checkpoint	Solution
Door stops during soft closing.	Check if door bottom contacts the floor.	Verify that the track fixing screws are not loosened. Then, adjust the door height such that the clearance between the door bottom and floor is 6 - 14 mm.
	Check if upper track is set horizontally.	Using a level gauge, reset upper track horizontally.
	Check if gasket seal is installed.	Reduce the friction between gasket and door.
The door doesn't close softly.	Check if trigger is installed.	Install trigger to correct position.
	Check if door is closed by excessive force.	Do not close door by excessive force as it may damage soft closer.
	The position of the trigger catcher in page 3 section 3 may become dislocated. (It is hidden as installed in upper track.)	Slowly move the door towards the leading edge, then push the door firmly. Repeat this action on the opposite side as well. If it is still not improved, check the status of the trigger catcher in section 3 .
Abnormal noise during operation	Check if door bottom contacts the floor or floor guide	Verify that the track fixing screws are not loosened. Then, adjust the door height such that the clearance between the door bottom and floor is 6 - 13 mm.
	Check track rollers for aluminum dust.	Remove the track and pull out the roller. Then, clean the roller.
	Check for loose screws retaining the upper track.	Tighten the screw.
Heavy door operation	Check if door bottom contacts the floor or floor guide	Verify that the track fixing screws are not loosened. Then, adjust the door height such that the clearance between the door bottom and floor is 6 - 13 mm.
Door starts to move.	Check if the upper track is set horizontally.	Using a level gauge, reset the upper track horizontally.

INSTALLATION DRAWING (EXAMPLE) (In this manual, a single sliding door is used as an example.)

※2 If the cross is to be rolled in, take its thickness into account.

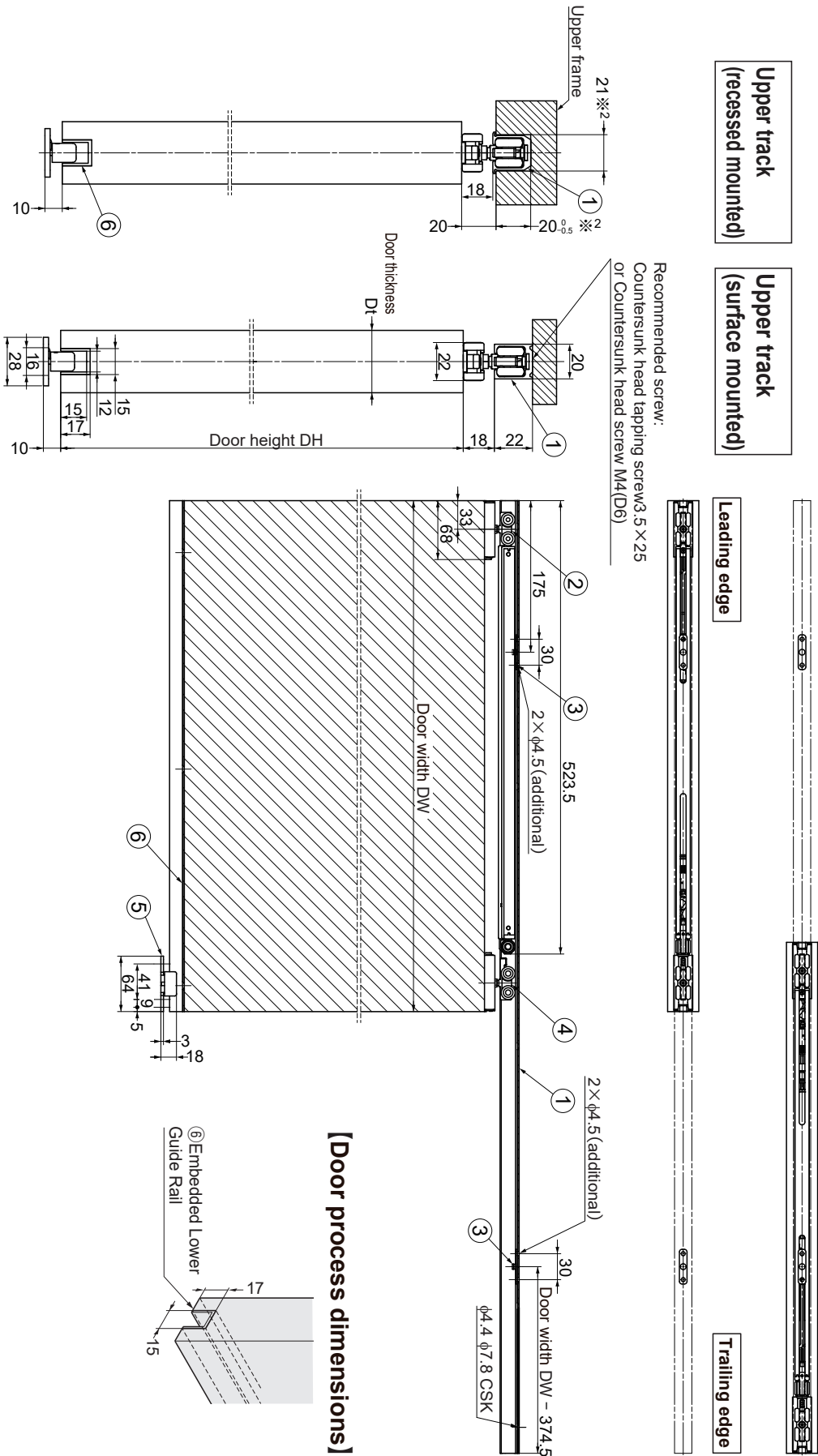

MEMO

SUGATSUNE KOGYO CO.,LTD**Tokyo, JAPAN**

Phone: +81 (0)3 3866 2260 E-mail:export@sugatsune.co.jp

SUGATSUNE KOGYO (UK) LTD**Reading, UK**

Phone: +44 118 9272 955 E-mail:sales@sugatsune.co.uk

SUGATSUNE EUROPE GmbH**Düsseldorf, GERMANY**

Phone: +49 211 53812900 E-mail:sales@sugatsune.eu

SUGATSUNE SHANGHAI Co., LTD**Shanghai, CHINA**

Phone: +86 21 3632 1858 E-mail:lamp@sugatsune.com.cn

Guangzhou, CHINA

Phone: +86 20 6639 3552 E-mail:lamp@sugatsune.com.cn

SUGATSUNE KOGYO INDIA PRIVATE LIMITED**Mumbai, INDIA**

Phone: +91 22 28314490/91 E-mail:sales@sugatsune.in

SUGATSUNE AMERICA, INC**California, USA**

Phone: +1 310 329 6373 E-mail:sales@sugatsune.com

Chicago, USA

Phone: +1 630 317 7072 E-mail:sales@sugatsune.com

SUGATSUNE CANADA, INC.

Phone: +1 514 312 5267 E-mail:support@sugatsune.ca

